

brother

本縫プログラム式電子ミシンプロファイルM
PROGRAMMABLE ELECTRIC LOCK STITCH SEWING MACHINE PROFILE M
M-FÖRMIGE PROGRAMMIERBARE ELEKTRISCHE VERRIEGELUNGSSTICH-
NÄHMASCHINE
MACHINE ELECTRIQUE A POINT NOUE PROGRAMMABLE PROFIL EN M
PERFIL M DE LA MAQUINA DE COSER DE DOBLE PESPUNTE ELECTRICA
PROGRAMABLE

BAS-302

パーツブック

PARTS BOOK

TEILEKATALOG

LIVRE DES PIECES

LIBRO DE REFERENCIA DE PIEZAS



Brother

本機は、縫製作業の効率化を図るために、最新の技術を搭載しています。また、縫製速度を調整できるため、様々な素材の縫製に対応しています。さらに、縫製した布地の歪みを軽減する機能も搭載しています。この機能は、縫製した布地の歪みを軽減し、縫製した布地の歪みを軽減します。また、縫製した布地の歪みを軽減する機能も搭載しています。この機能は、縫製した布地の歪みを軽減し、縫製した布地の歪みを軽減します。



パーツブックご利用に際して

1. 部品コード欄または組コード欄が ・ となっている場合は、仕様別部品一覧表（23ページ）でお調べ下さい。
2. 部品コード欄が となっている部品は補給いたしません。ただし組コードが記載されているものは、組部品として補給いたしますのでご注文下さい。
3. この本は1984年5月のデータにもとづいて作成されたものです。
4. 部品は、予告なしに設計変更される場合があります。

目 次

A. 主体・針板・モータ関係	1	L. 糸巻装置	13
B. 針棒・天ピン関係	2	M. 電装品関係 (1)	14
C. 押工関係	3	M. 電装品関係 (2)	15
D. カマ関係	4	N. 押工アクチュエータ関係	16
E. 給油・潤滑・押工上げ関係	5	P. 動力台関係 (1)	17
F. 糸通シ・糸ユルメ関係	6	P. 動力台関係 (2)	18
G. 糸切り関係	7	Z. 付属品関係	19
H. 押工関係 (1)	8	Z. 付属装置関係	20
H. 押工関係 (2)	9	特別注文部品 (1)	21
J. 駆動側送り関係 (1)	10	特別注文部品 (2)	22
J. 駆動側送り関係 (2)	11	仕様別部品一覧表	23
K. 送り案内関係	12	索引	24

Notes for using this parts book

1. If the symbol or 000000-000 is in the "Parts No." column or the "Assembly No." column, please refer to the different parts list (page 23).
2. The symbol in the "Parts No." column indicates that the parts is not available for supply. If, however, there is a number in the "Assembly No." column, the parts can be ordered as an assembly. Please, therefore, order by using the assembly number.
3. This book was prepared based on information available in May, 1984.
4. Parts are subject to changes in design without prior notice.

CONTENT

<p>A. Machine Body, Needle Plate and Motor Mechanism 1</p> <p>B. Needle Bar and Thread Take-Up Mechanism 2</p> <p>C. Presser Foot Mechanism 3</p> <p>D. Rotary Hook Mechanism 4</p> <p>E. Lubrication Work Clamp Lifter Mechanism 5</p> <p>F. Threading, Tension Release Mechanism 6</p> <p>G. Thread Trimmer Mechanism 7</p> <p>H. Presser Foot Mechanism (1) 8</p> <p>H. Presser Foot Mechanism (2) 9</p> <p>J. Feed Guide Mechanism (1) 10</p> <p>J. Feed Guide Mechanism (2) 11</p> <p>K. Feed Guide Mechanism 12</p>	<p>L. Bobbin Winder Mechanism 13</p> <p>M. Power Supply Equipment Mechanism (1) 14</p> <p>M. Power Supply Equipment Mechanism (2) 15</p> <p>N. Actuator Mechanism 16</p> <p>P. Power Table (1) 17</p> <p>P. Power Table (2) 18</p> <p>Z. Accessories (1) 19</p> <p>Z. Accessories (2) 20</p> <p>OPTION PARTS (1) 21</p> <p>OPTION PARTS (2) 22</p> <p>DIFFERENT PARTS LIST 23</p> <p>INDEX 24</p>
---	---

Anmerkungen zum Gebrauch dieses Stücklistebuches

1. Wenn in der stücknummer oder Gerätesatznummer Spalte das Zeichen oder 000000-000 steht, schlagen Sie bitte bei der gesonderte Stückliste (Seite 23) nach.
2. Dieses Zeichen in der Spalte "Teilnummer" bedeutet, daß dieser Teil nicht lieferbar ist. Wenn jedoch in der Spalte "Gerätesatznummer" eine Nummer steht, kann dieser Teil als ein Geräteteilsatz bestellt werden. Bestellen Sie daher bitte mit dieser Gerätesatznummer.
3. Dieses Buch basiert auf den Informationen vom Mai 1984.
4. Modelländerungen sind vorbehalten.

INHALTSVERZEICHNIS

<p>A. Maschinengehäuse, Stichplatte und Motor 1</p> <p>B. Nadelstange und Fadenabnahme vorrichtung 2</p> <p>C. Stoffdrückerfuß 3</p> <p>D. Greifervorrichtung 4</p> <p>E. Schmierung, Stoffhalterhebervorrichtung 5</p> <p>F. Fadenführung, Spannungsverminderungsvorrichtung 6</p> <p>G. Fadenabschneidevorrichtung 7</p> <p>H. Stoffdrückerfuß (1) 8</p> <p>H. Stoffdrückerfuß (2) 9</p> <p>J. Transportführung (1) 10</p>	<p>J. Transportführung (2) 11</p> <p>K. Transportführung 12</p> <p>L. Spuler 13</p> <p>M. Stromversorgung (1) 14</p> <p>M. Stromversorgung (2) 15</p> <p>N. Stoffdrückerbetätigung 16</p> <p>P. Motorgestell (1) 17</p> <p>P. Motorgestell (2) 18</p> <p>Z. Zubehör (1) 19</p> <p>Z. Zubehör (2) 20</p> <p>SONDERZUBEHÖR (1) 21</p> <p>SONDERZUBEHÖR (2) 22</p> <p>ZUBEHÖRLISTE 23</p> <p>INHALTSVERZEICHNIS 24</p>
---	---

Notes sur l'utilisation de ce manuel de pièces détachées

1. Si le symbole ou 000000-000 est présent dans la colonne "No. de pièce" ou dans la colonne "No. de ensemble", se référer à la liste de pièces annexe (page 23).
2. Le symbole dans la colonne "N° de pièce" signifie que la pièce ne peut être fournie. Si, dans la colonne "N° jeu de pces", il y a un numéro de nomenclature, la pièce peut être commandée comme faisant partie d'un jeu de pièces. Donc, pour toute commande, veuillez spécifier le n° du jeu de pièces.
3. Ce manuel a été fait d'après les renseignements valables au mois de Mai 1984.
4. Les pièces peuvent être sujettes à des modifications sans préavis.

TABLE DES MATIERES

<p>A. Corps de la machine, aiguille en place du moteur 1</p> <p>B. Mécanisme de la barre à aiguille et releveur de fil 2</p> <p>C. Mécanisme du pied presseur 3</p> <p>D. Mécanisme du crochet rotatif 4</p> <p>E. Lubrification, mécanisme de leveur du pinceur 5</p> <p>F. Mécanisme de l'eufilage, relachete-nsion 6</p> <p>G. Mécanisme de coupe-fil 7</p> <p>H. Mécanisme du pied presseur (1) 8</p> <p>H. Mécanisme du pied presseur (2) 9</p> <p>J. Mécanisme du guide de l'entraînemnt (1) 10</p> <p>J. Mécanisme du guide de l'entraînemnt (2) 11</p>	<p>K. Mécanisme du guide de l'entraînement .. 12</p> <p>L. Mécanisme du bobineur 13</p> <p>M. Mécanisme de l'équipement en alimentation électrique (1) 14</p> <p>M. Mécanisme de l'équipement en alimentation électrique (2) 15</p> <p>N. Mécanisme de l'actuateur 16</p> <p>P. Mécanisme du plateau de la machine (1) 17</p> <p>P. Mécanisme du plateau de la machine (2) 18</p> <p>Z. Accessoires (1) 19</p> <p>Z. Accessoires (2) 20</p> <p>PIECES EN OPTION (1) 21</p> <p>PIECES EN OPTION (2) 22</p> <p>LISTE DES PIECES ACCESSOIRES 23</p> <p>INDEX 24</p>
--	--

Notas para usar este libro de Piezas

1. De haber el símbolo o el 000000-000 en la columna del "Número de Pieza" o en la del "Número de Juego", habrá que ver la lista de piezas separada (página 23).
2. El símbolo que se encuentra en la columna del "Número de Pieza", quiere decir que no se dispone de dicha pieza sola. Cuando, empero, hay un número en la columna del "Número de Juego", se podrá ordenar la pieza con todo el juego. Por lo tanto, será mejor hacer el pedido recurriendo al número del juego respectivo.
3. Este libro ha sido compilado basándose en los datos de que se disponía en mayo de 1984.
4. Las piezas quedan sujetas a cambios de diseño sin aviso previo.

INDICE

<p>A. Cuerpo de la máquina, aguja l'a placa y motor 1</p> <p>B. Mecanismo de la barra de aguja y tirahilos 2</p> <p>C. Mecanismo del prensa telas 3</p> <p>D. Mecanismo del cangrejo 4</p> <p>E. Lubricación, mecanismo de levantador de ménsula de trabajo 5</p> <p>F. Mecanismo de la enhebrado, l'iberador de tensión 6</p> <p>G. Mecanimo de le cortadora de orillos 7</p> <p>H. Mecanismo del presa telas (1) 8</p> <p>H. Mecanismo del presa telas (2) 9</p> <p>J. Mecanismo de la guía de alimentación (1) 10</p>	<p>J. Mecanismo de la guía de alimentación (2) 11</p> <p>K. Mecanismo de la guía de alimentación .. 12</p> <p>L. Mecanismo del devandor de la canilla 13</p> <p>M. Mecanismo de la equipo de alimentación de corriente (1) 14</p> <p>M. Mecanismo de la equipo de alimentación de corriente (2) 15</p> <p>N. Mecanismo del impulsor 16</p> <p>P. Mecanismo del mesa de la máquina (1) 17</p> <p>P. Mecanismo del mesa de la máquina (2) 18</p> <p>Z. Accesorios (1) 19</p> <p>Z. Accesorios (2) 20</p> <p>PIEZAS OPCION (1) 21</p> <p>PIEZAS OPCION (2) 22</p> <p>LISTA DE PIEZAS ACCESORIAS 23</p> <p>INDICE 24</p>
--	--

A. 主体・針板・モータ関係

Machine Body, Needle Plate and Motor Mechanism/Maschinengehäuse, Stichplatte und Motor
 Corps de la machine, aiguille en Place du moteur/Cuerpo de la máquina, aguja l'a Placa y motor

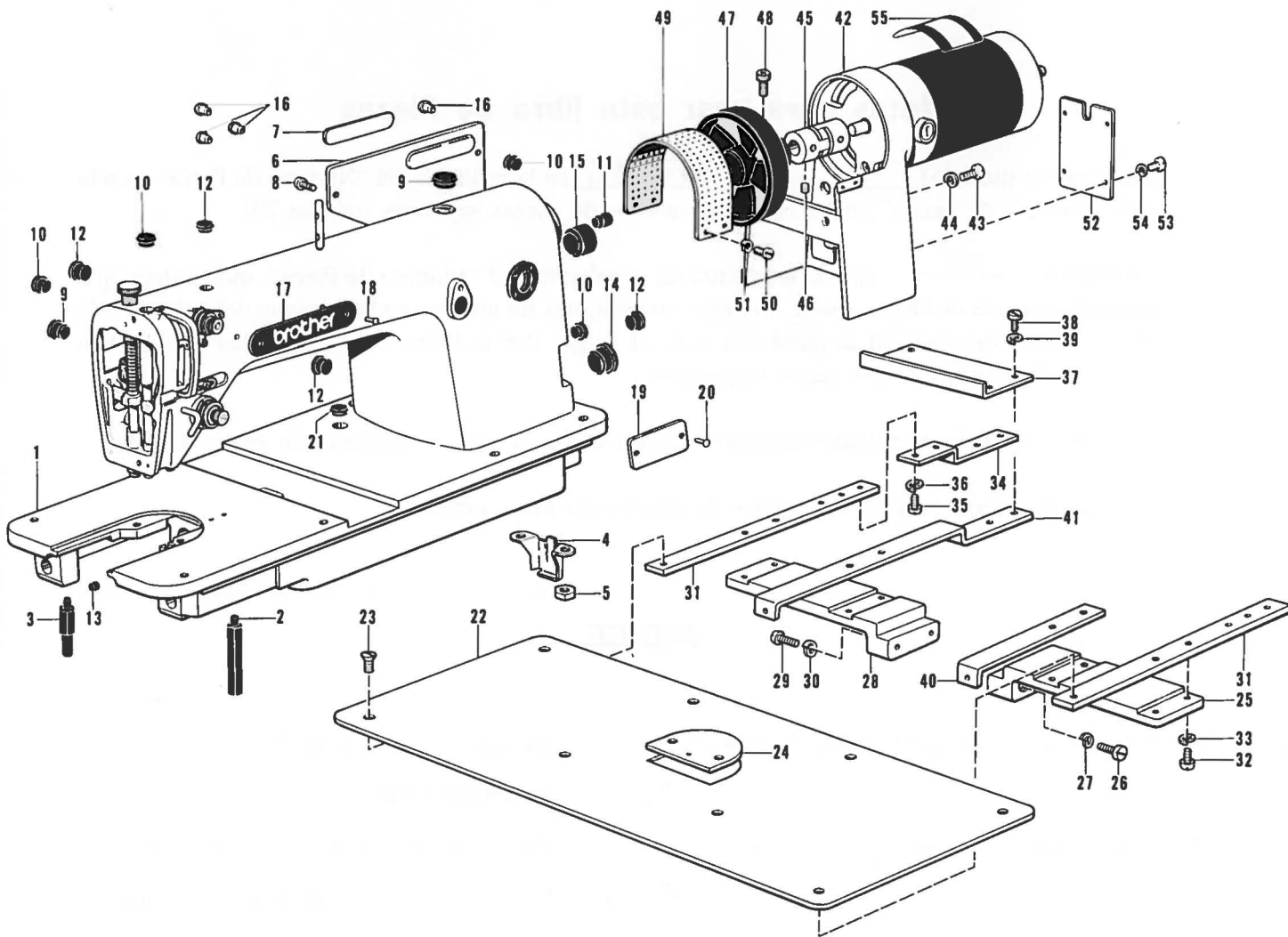

Ref. No.	Name of Parts	Q'ty	Parts No.	Ref. No.	Name of Parts	Q'ty	Parts No.
1	Arm Bed	1		29	Screw	シメネシ 4.37	2 102424-004
2	Bed Leg(L)	1	104829-101	30	Spring Washer	バネザガネ 2-4.37	2 028680-242
3	Bed Leg(S)	1	104830-101	31	Plate For Needle Plate	ハリイタトリツケイタ	2 152259-101
4	Pump Cover	1	145454-001	32	Screw	ヒラネジ 4X10	8 007401-012
5	Nut	2	100090-004	33	Spring Washer	バネザガネ 2-4	8 028040-242
6	Rear Cover	1	145455-002	34	Cover Setting Plate	カバトリツケイタ	1 154122-001
7	Name Plate brother	1		35	Screw	ヒラネジ 4X10	2 007401-012
8	Screw	5	062670-812	36	Spring Washer	バネザガネ 2-4	2 028040-242
9	Oil Cap	3	104449-001	37	Rear Cover	ハリイタコウカバー	1 154121-001
10	Oil Cap	4	104450-001	38	Screw	ヒラネジ 3X6	2 007300-612
11	Oil Cap	1	104832-001	39	Spring Washer	バネザガネ 2-3	2 028030-242
12	Oil Cap	4	104821-001	40	Cover Supporter Plate(Right)	カマカバーササエミギ	1 152634-001
13	Cap	1	142274-001	41	Cover Supporter Plate(Left)	カマカバーササエヒダリ	1 154123-001
14	Oil Cap	1	108520-001	42	D.D.Motor Bracket Assembly	DD モータブラケットクミ	1 152383-201
15	Oil Cap	1	104451-001	43	Screw	ナベコ 595-28X16	2 062761-612
16	Oil Cap	4	111865-001	44	Spring Washer	バネザガネ 2-6	2 028060-242
17	Name Plate brother	1		45	Coupling Assembly	カップリングクミ	1 152593-000
18	Pin	2		46	Screw	アナトメネジ 6.35 クボミ	4 014770622
19	Name Plate	1		47	Pulley	プーリ	1 152389-001
20	Pin	2		48	Bolt	アナボルト MSX12	2 018501-222
21	Oil Cap	1	117936-001	49	Pulley Cover	プーリカバー	1 152390-002
22	Needle Plate SUS	1	152255-000	50	Screw	ヒラネジ 2.6X6	4 007260-612
23	Screw	8	100032-004	51	Spring Washer	バネザガネ 2-2.6	4 028260-242
24	Needle Plate	1	152256-001	52	Motor Bracket Cover	モータブラケットカバー	1 154032-002
25	Needle Plate Supporter(Right)	1	152257-001	53	Screw	ヒラネジ 3X6	4 007300-613
26	Screw	2	102424-004	54	Spring Washer	バネザガネ 2-3	4 028030-243
27	Spring Washer	2	028680-242	55	Label	DDモータメイバン	1
28	Needle Plate Supporter(Left)	1	152258-101				

B. 針棒・天ビン関係

Needle Bar and Thread Take-Up Mechanism / Nadelstange und Fadenabnahme vorrichtung

Mécanisme de la barre à aiguille et releveur de fil / Mecanismo de la barra de aguja y tirahilos

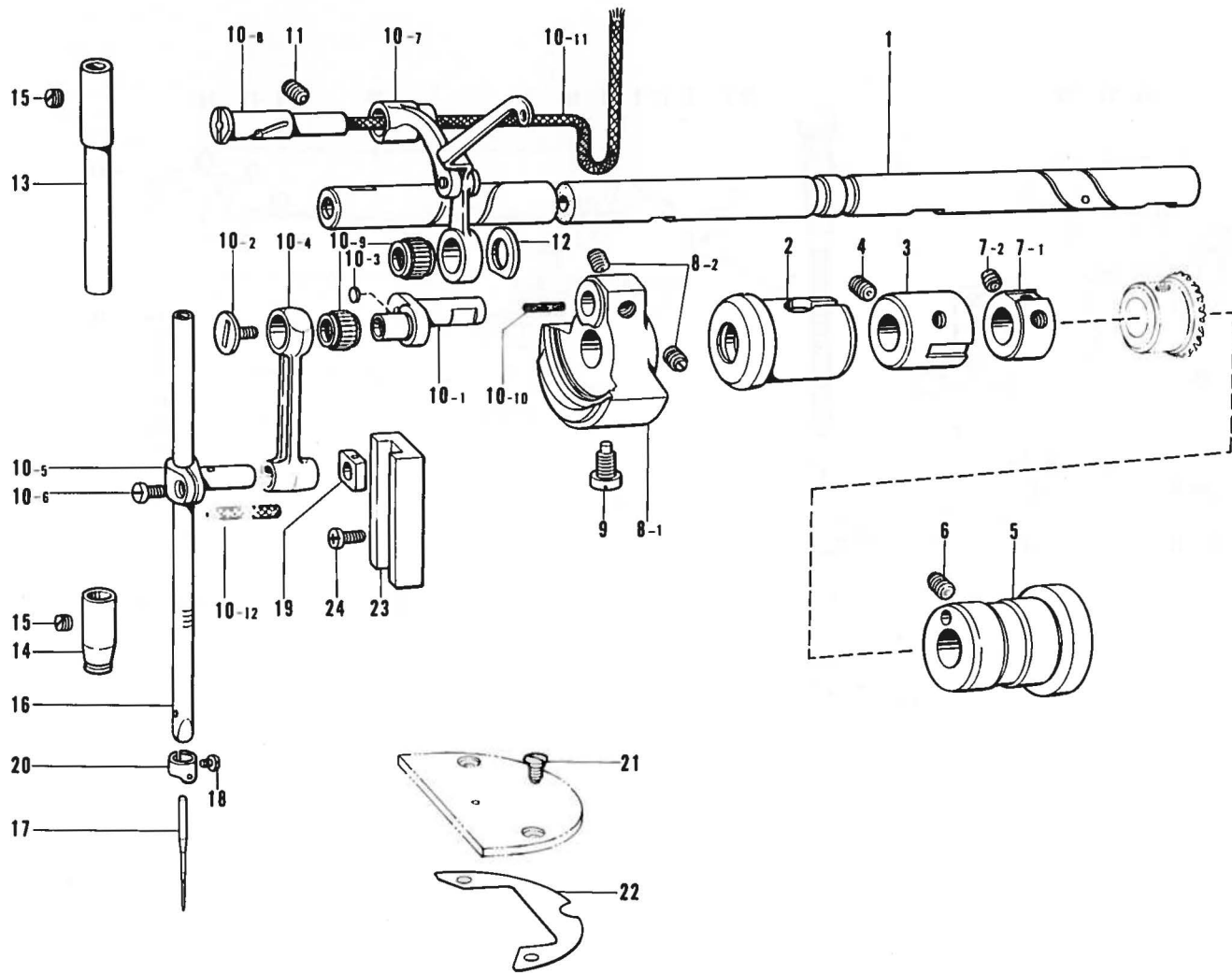

Ref. No.	Name of Parts	Q'ty	Parts No.	Ref. No.	Name of Parts	Q'ty	Parts No.
1	Upper Shaft	1	147511-001	10- 7	Thread Take-Up Supporter Assembly	1	181429-101
2	Upper Shaft Bushing(Left)	1	145459-101	10- 8	Stud	1	-----
3	Upper Shaft Bushing(Intermediate)	1	140726-000	10- 9	Bearing	2	147777-000
4	Screw	1	013760-610	10-10	Felt	1	145624-000
5	Upper Shaft Bushing(Right)	1	145461-101	10-11	Wick	1	158726-001
6	Screw	1	013760-610	10-12	Wick	1	158727-001
7	Pulley Bush Assembly	3	118371-001	11	Screw	1	013781-012
7- 1	Collar	3	-----	12	Washer	1	110367-001
7- 2	Screw	6	100251-001	13	Needle Bar Bushing(Upper)	1	111463-001
8	Thread Take-Up Crank Assembly	1	159698-001	14	Needle Bar Bushing(Lower)	1	147326-001
8- 1	Thread Take-Up Crank	1	-----	15	Screw	2	100260-001
8- 2	Screw	2	100251-001	16	Needle Bar	1	145986-001
9	Screw	1	104464-001	17	Needle	1	107415-022
10	Thread Take-Up Lever Assembly	1	149313-101	18	Screw	1	140553-102
10- 1	Needle Bar Crank	1	-----	19	Needle Bar Guide Slide Block	1	102630-001
10- 2	Screw	1	145465-001	20	Thread Guide	1	151594-001
10- 3	Cap	1	145600-000	21	Screw	2	100032-004
10- 4	Needle Bar Crank Rod	1	145466-001	22	Washer	1	146251-001
10- 5	Needle Bar Clamp	1	111237-001	23	Needle Bar Guide	1	145688-000
10- 6	Screw	1	140004-001	24	Screw	2	062670-612

C. 押工関係

Presser Foot Mechanism/Stoffdrückerfuß

Mécanisme du pied presseur/Mecanismo del prensa telas

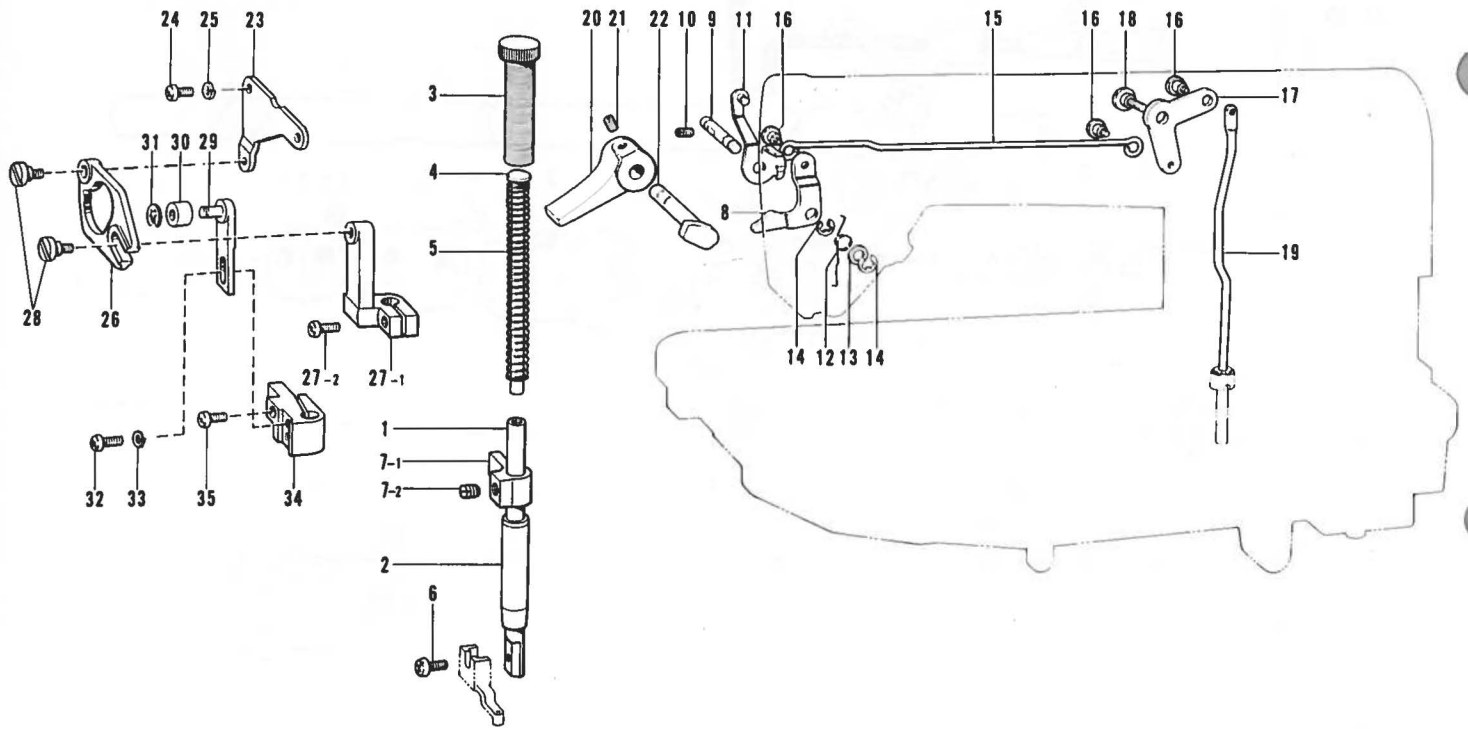

Ref. No.	Name of Parts	Q'ty	Parts No.	Ref. No.	Name of Parts	Q'ty	Parts No.
1	Presser Bar	1	111466-001	19	Knee Lifter Bar	1	145481-001
2	Presser Bar Bushing	1	145472-001	20	Presser Bar Lifter	1	145482-001
3	Screw	1	157505-001	21	Screw	1	014710-522
4	Presser Spring Guide	1	141208-001	22	Presser Bar Lifter Clank	1	145483-001
5	Presser Spring(C)	1	154115-001	23	Stepping Foot Drving Cam Bracket	1	154146-001
6	Screw	1	060671-012	24	Screw	2	062681-012
7	Presser Bar Clamp Assembly	1	181919-001	25	Spring Washer	2	028680-242
7- 1	Presser Bar Clamp	1	147513-001	26	Stepping Foot Driving Cam	1	154147-001
7- 2	Screw	1	013760-610	27	Needle Cramp With Screw	1	183148-001
8	Presser Bar Lifter Lever	1	145580-001	27- 1	Needle Clamp For Stepping Foot	1	154148-001
9	Presser Bar Lifter Lever Stud	1	145474-001	27- 2	Screw	1	062681-212
10	Screw	1	100128-002	28	Stud Screw	2	154149-001
11	Tension Releaser	1	S00839-001	29	Rollar Shaft	1	155051-001
12	Spring	1	145475-101	30	Rollar	1	155052-001
13	Washer	2	109763-002	31	Stop Ring	1	048050-342
14	Stop Ring	2	048040-342	32	Screw	2	062681-012
15	Knee Lifter Connector	1	154550-001	33	Spring Washer	2	028680-242
16	Stud Screw	3	145478-001	34	Presser Bar Guide Bracket	1	154150-001
17	Knee Lifter Lever	1	145479-001	35	Screw	1	062681-212
18	Stud Screw	1	145480-001				

D. カマ関係
 Rotary Hook Mechanism / Greifervorrichtung
 Mécanisme du crochet rotatif / Mecanismo del cangrejo

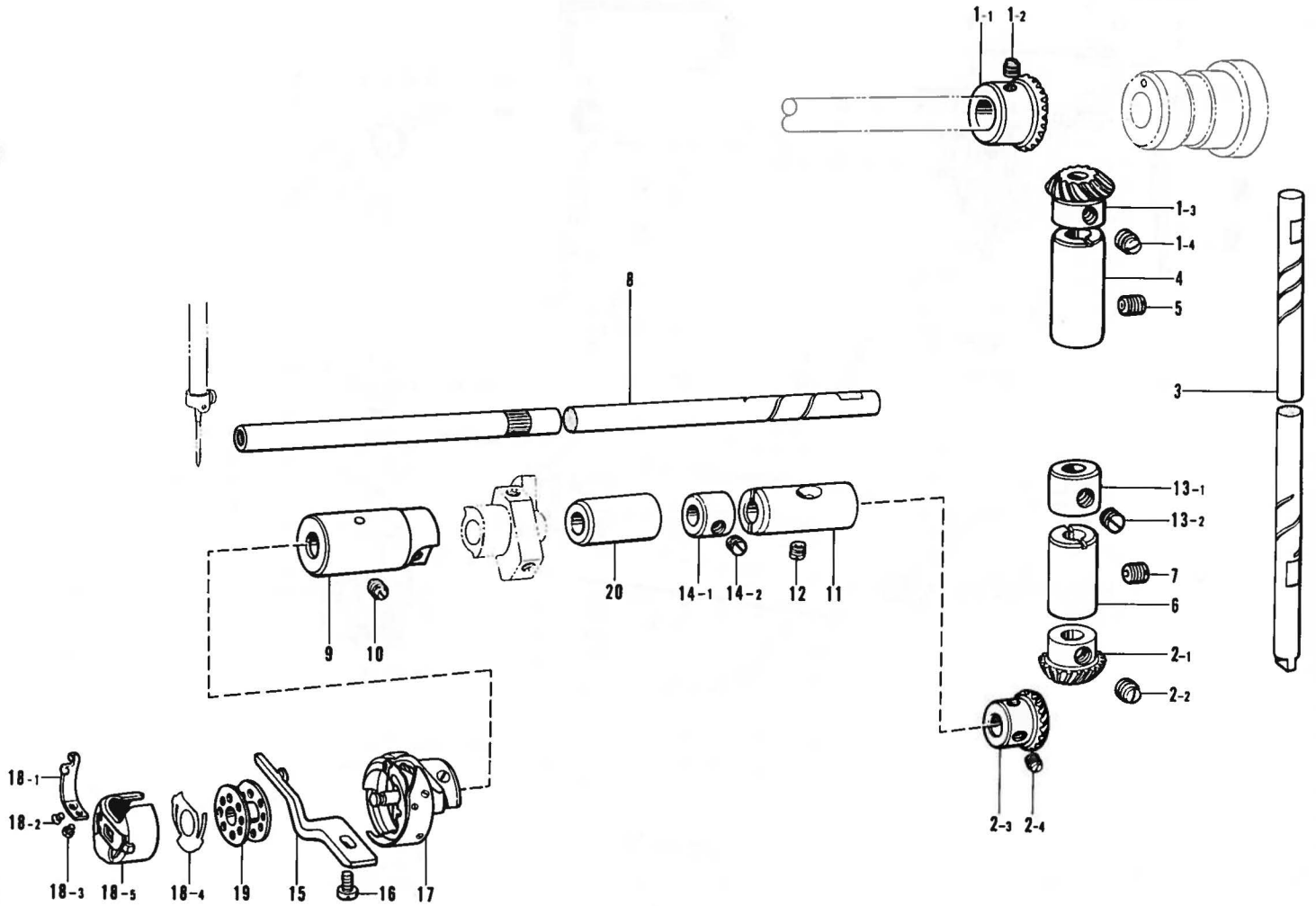

Ref. No.	Name of Parts	Q'ty	Parts No.	Ref. No.	Name of Parts	Q'ty	Parts No.
1	Bevel Gear Upper Assembly	1	140378-001	12	Screw	1	151607-001
1-1	Upper Shaft Gear	1	ウワジクベベルギヤ	13	Collar Assembly	1	181995-001
1-2	Screw	2	トメネジ 6.35	13-1	Set Collar	1	セットカラー
1-3	Vertical Shaft U Gear	1	タテジクベベルギヤ U	13-2	Screw	2	101706-001
1-4	Screw	2	トメネジ 6.35	14	Collar Assembly	1	181995-001
2	Bevel Gear Lower Assembly	1	140381-001	14-1	Set Collar	1	セットカラー
2-1	Vertical Shaft D Gear	1	タテジクベベルギヤ D	14-2	Screw	2	101706-001
2-2	Screw	2	トメネジ 6.35	15	Bobbin Case Holder Position Bracket	1	159324-001
2-3	Lower Shaft Gear	1	シタジクベベルギヤ	16	Screw	1	062681-212
2-4	Screw	2	トメネジ 6.35	17	Rotary Hook Assembly	1	155690-001
3	Vertical Shaft	1	145516-001	18	Bobbin Case Assembly	1	148350-101
4	Vertical Shaft Upper Bushing	1	142708-000	18-1	Spring	1	183291-001
5	Screw	1	トメネジ 5.95 クボミ	18-2	Screw	1	183292-001
6	Vertical Shaft Lower Bushing	1	142709-000	18-3	Screw	1	183293-001
7	Screw	1	トメネジ 5.95 クボミ	18-4	Bobbin Tension Spring	1	148967-101
8	Lower Shaft	1	154552-001	18-5	Bobbin Case	1	ボビンケースタイ
9	Lower Shaft Bushing(Left)	1	118761-000	19	Bobbin	1	117132-001
10	Screw	1	トメネジ 4.37 ヒラ	20	Lower Shaft Bushing Middel	1	118762-000
11	Lower Shaft Bushing(Right)	1	104520-000				

E. 給油・潤滑・押エ上ゲ関係

Lubrication Work Clamp Lifter Mechanism/Schmierung, Stoffhalterhebevorrichtung

Lubrification, mécanisme de leueur du pinceur / Lubricación, mecanismo de levantador de ménsula de trabajo

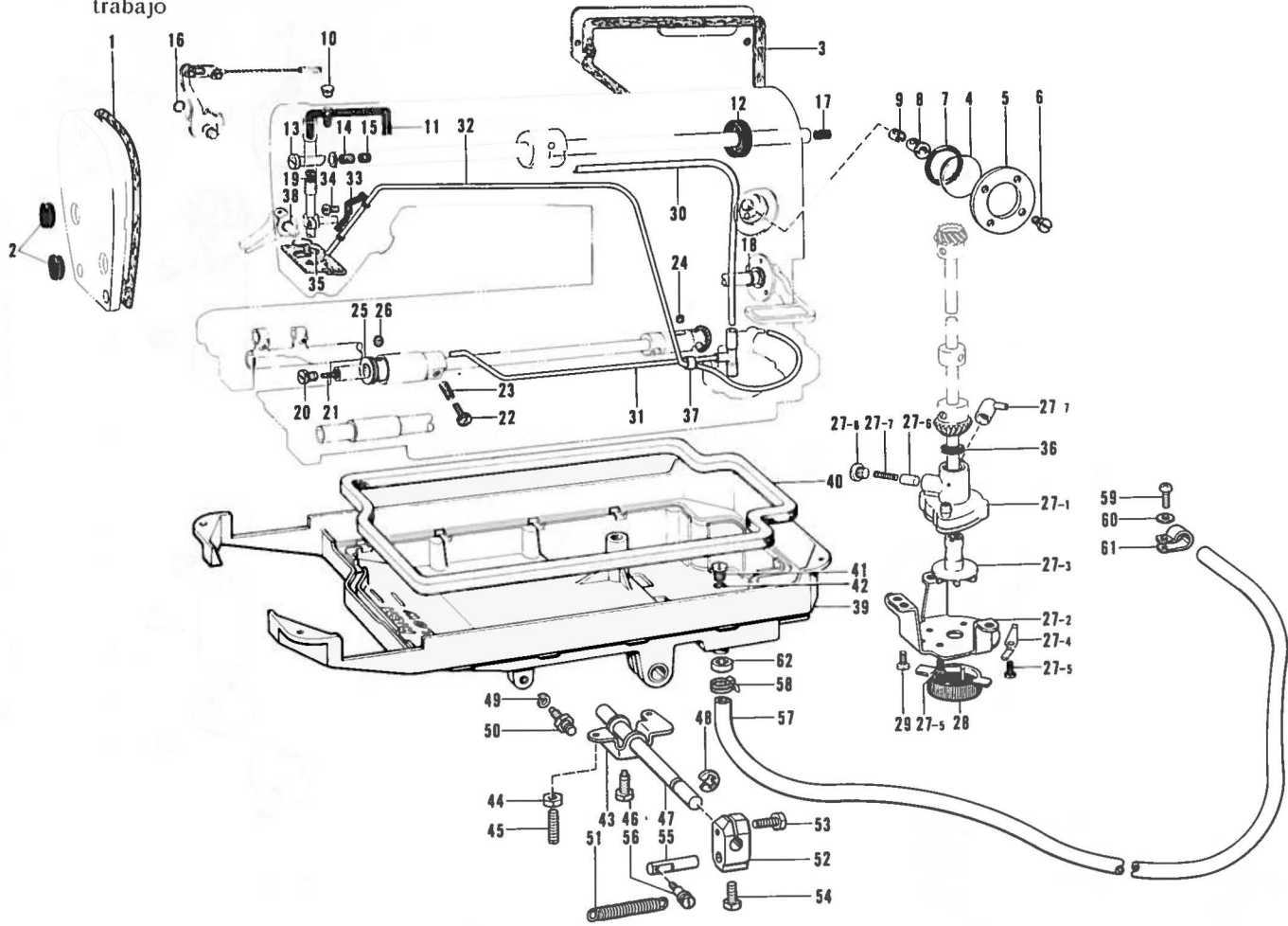

Ref. No.	Name of Parts	Q'ty	Parts No.	Ref. No.	Name of Parts	Q'ty	Parts No.
1	Packing	1	145527-000	28	Pump Filter	1	144872-001
2	Oil Cap	2	104449-001	29	Screw	3	062680-712
3	Packing	1	145528-000	30	Oil Tube(Upper)	1	147496-000
4	Oil Gauge Window	1	104547-001	31	Oil Tube(D)Assembly	1	154555-001
5	Oil Gauge Cap	1	151074-001	32	Tube Assembly	1	145543-001
6	Screw	4	100257-010	33	Tube Holder	1	145547-001
7	"O" Ring	1	081014-670	34	Screw	1	062670-516
8	Tube Holder	1	145529-000	35	Felt Support	1	145737-001
9	Tube Holder Cap	1	146314-000	36	Oil Stopper	1	146196-001
10	Oil Cap	1	111865-001	37	Tube	1	146253-000
11	Wick	1	108804-001	38	"O" Ring	1	081001-670
12	Oil Seal	1	101487-000	39	Oil Pan	1	152284-100
13	Oil Control Valve	1	146333-001	40	Packing	1	146040-001
14	Felt	1	146327-001	41	Screw	1	140518-001
15	Felt	1	107149-001	42	"O" Ring	1	081007-070
16	"O" Ring	1	081001-670	43	Knee Lifter	1	146037-001
17	Oil Cap	1	156641-001	44	Nut	2	100022-004
18	"O" Ring	1	104564-001	45	Screw	2	104885-001
19	Needle Bar Cork	1	111863-001	46	Bolt	1	146367-001
20	Screw	1	109173-001	47	Knee Lifter Shaft	1	146069-001
21	Felt	1	145751-001	48	Stop Ring	1	146293-001
22	Screw	1	145534-001	49	Spring Washer	1	028060-242
23	Spring	1	116794-001	50	Screw	1	147141-001
24	Felt	1	107155-001	51	Spring	1	152285-001
25	Oil Rejector	1	154554-001	52	Knee Lifter Joint	1	146039-001
26	Screw	2	102716-001	53	Bolt	1	017762-013
27	Pump Body Assembly	1	181476-201	54	Bolt	4	100463-001
27- 1	Pump Body	1		55	Piston Drive Link	1	152286-001
27- 2	Pump leg	1	144869-002	56	Screw	1	152287-001
27- 3	Pump rotor	1	148849-001	57	Tube	1	152288-000
27- 4	Spring	2	144874-001	58	Band	1	152289-000
27- 5	Screw	4	062670-812	59	Screw	1	002401-012
27- 6	Plunger	1	144875-001	60	Washer	1	025040-232
27- 7	Spring	1	144876-001	61	Cord Holder	1	554482-000
27- 8	Screw	1	112467-002	62	Nut	1	155077-000
27- 9	Joint	1	144878-001				

F. 糸通シ・糸ユルメ関係

Threading, Tension Release Mechanism/Fadenführung, Spannungsverminderungs-vorrichtung
 Mécanisme de l'eufilage, relachete-nsion/Mecanismo de la enhebrado, l'iberador de tensión

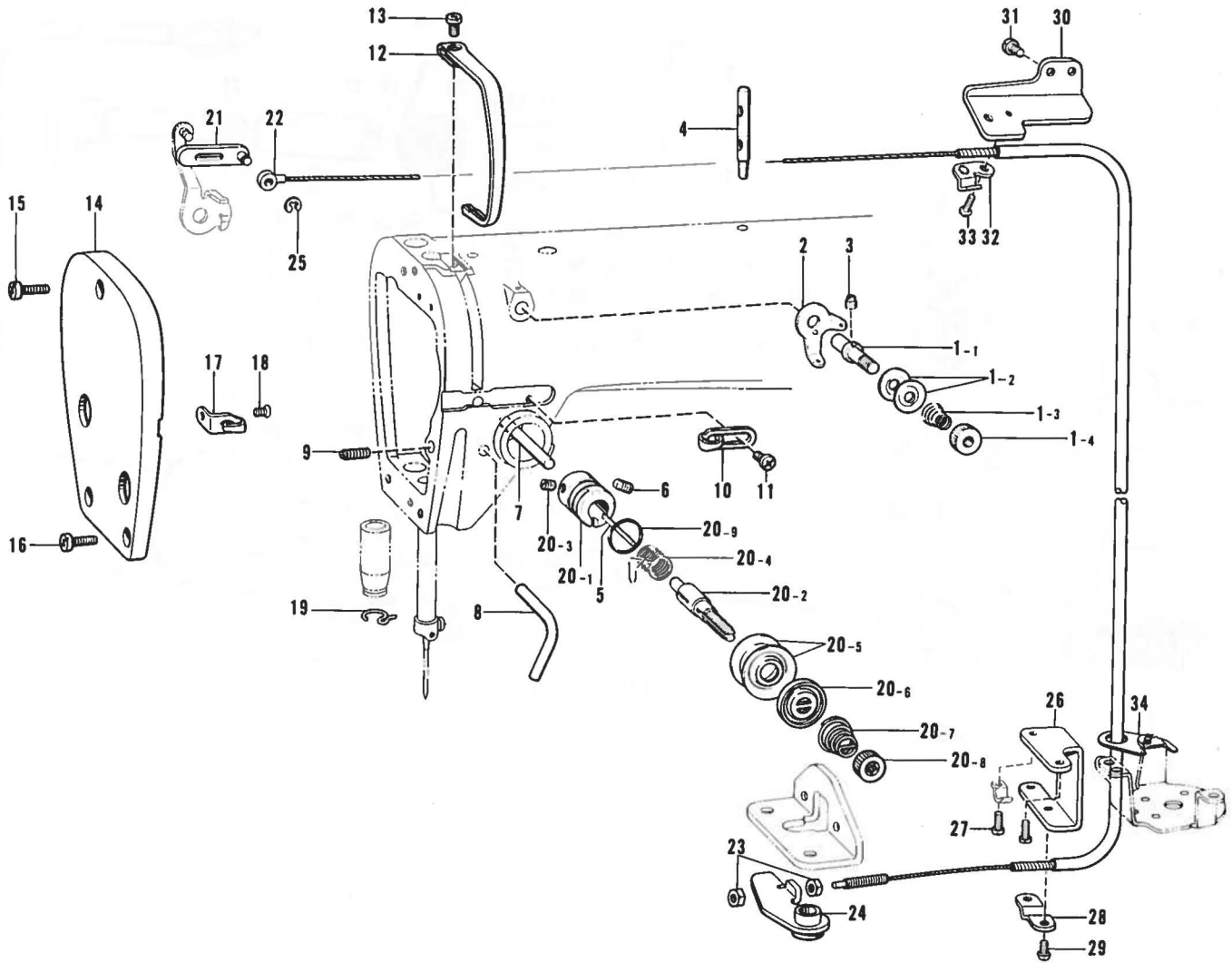

Ref. No.	Name of Parts	Q'ty	Parts No.	Ref. No.	Name of Parts	Q'ty	Parts No.
1	Pre Tension Assembly(B)	1	183125-001	20- 1	Tension Regulator Bracket	1	
1- 1	Pre Tension Stud	1	154559-001	20- 2	Tension Stud	1	100398-001
1- 2	Thread Guide Disc	2	144504-001	20- 3	Screw	1	100402-004
1- 3	Spring(B)	1	154562-001	20- 4	Thread Take-Up Spring	1	145519-001
1- 4	Nut	1	155510-001	20- 5	Tension Disc	2	145446-001
2	Thread Guide	1	154563-001	20- 6	Tension Disc Washer	1	159805-001
3	Screw	1	151602-002	20- 7	Spring	1	148924-101
4	Spool Stud	1	147557-101	20- 8	Tension Control Nut	1	100136-001
5	Tension Release Pin	1	100400-000	20- 9	"O" Ring	1	114294-001
6	Screw	1	103950-003	21	Tension Releasing Lever	1	154601-001
7	Tension Release Stud	1	145691-001	22	Tension Releasing Wire	1	154602-001
8	Thread Guide	1	116112-001	23	Nut	2	110161-004
9	Screw	1	153483-001	24	Tension Releasing Connecting Assembly	1	154603-001
10	Thread Guide(R)	1	145522-001	25	Stop Ring	1	048030-342
11	Screw	1	062670-612	26	Tension Releasing Wire Holder D	1	154606-001
12	Thread Take-Up Cover	1	140885-005	27	Screw	2	062670-812
13	Screw	1	062680-712	28	Tension Releasing Wire Presser D	1	154607-001
14	Face Plate	1	145523-102	29	Screw	2	060670-612
15	Screw	1	062672-012	30	Tension Releasing Wire Holder U	1	154608-001
16	Screw	2	062671-012	31	Screw	2	062670-612
17	Face Plate Thread Guide	1	111476-001	32	Tension Releasing Wire Presser U	1	149135-101
18	Screw	1	108960-002	33	Screw	1	060670-612
19	Thread Guide Under	1	100573-001	34	Tension Releasing Wire Guide	1	155347-001
20	Tension Regulator Assembly	1	183129-001				

G. 糸切り関係

Thread Trimmer Mechanism / Fadenabschneidevorrichtung
 Mécanisme de coupe-fil / Mecanimo de le cortadora de orillos

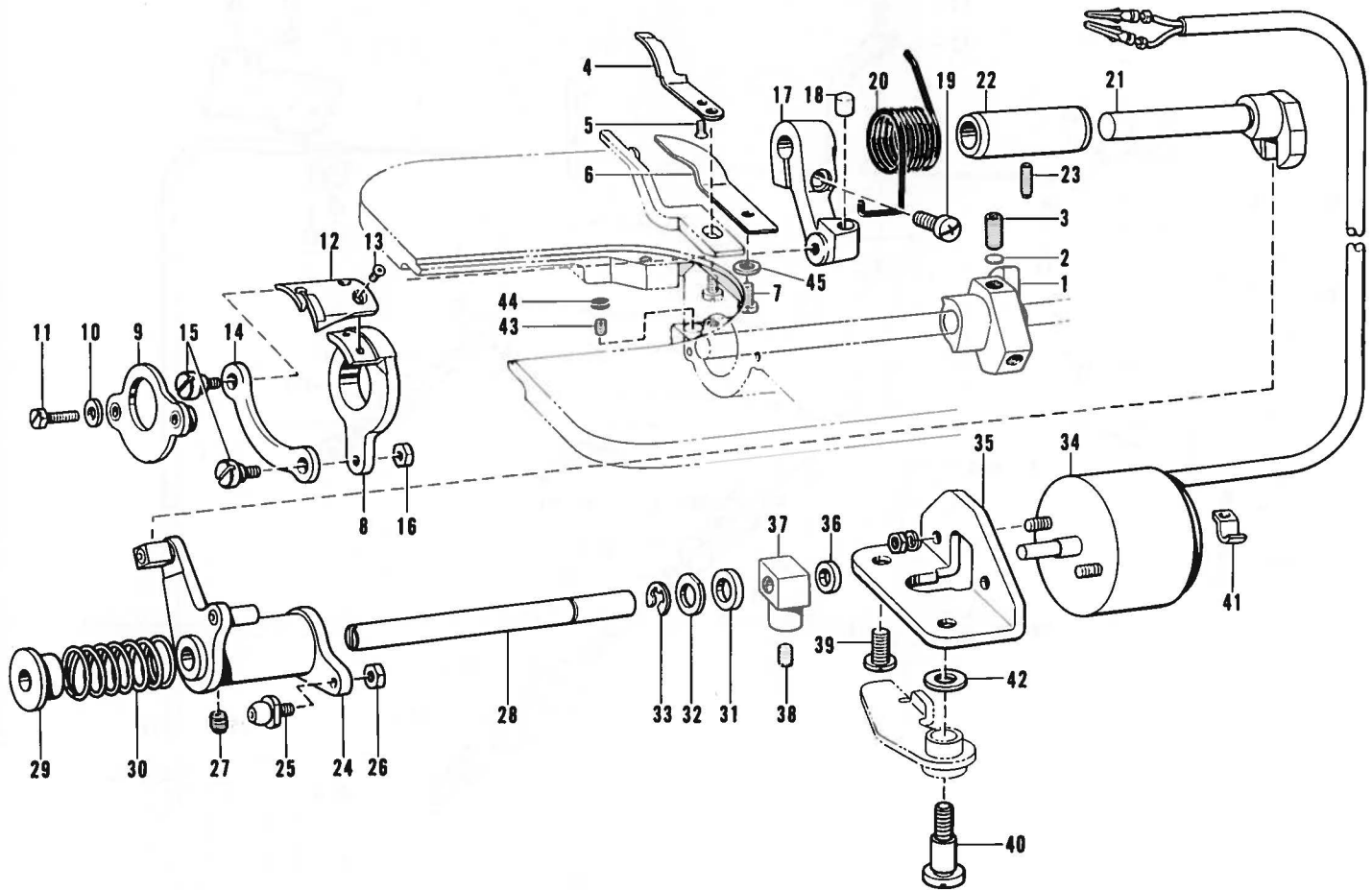

Ref. No.	Name of Parts	Q'ty	Parts No.	Ref. No.	Name of Parts	Q'ty	Parts No.
1	Thread Cutter Cam	1	154566-001	24	Thread Cutter Cam Lever Assembly	1	154582-001
2	Washer	2	154567-000	25	Screw	1	154590-001
3	Screw	2	014771-022	26	Nut	1	105234-003
4	Stationary Knife	1	154568-001	27	Screw	1	100251-001
5	Screw	1	102843-004	28	Lever Stud	1	154593-001
6	Lower Thread Finger	1	154569-001	29	Collar	1	154594-000
7	Screw	1	062680-712	30	Spring	1	154595-001
8	Thread Cutter Holder	1	154570-001	31	Rubber Cushion	1	154596-000
9	Thread Cutter Holder Presser Assembly	1	154571-001	32	Washer	1	110367-001
10	Washer	2	100645-003	33	Stop Ring	1	048060-342
11	Bolt	2	154574-001	34	Thread Cutter Solenoid	1	154597-001
12	Movable Knife	1	154575-001	35	Solenoid Bracket	1	154598-001
13	Screw	2	148537-001	36	Cushion	1	154599-000
14	Thread Cutter Connecting	1	154576-001	37	Solenoid Lever	1	154600-001
15	Stud Screw	2	151987-001	38	Screw	1	014680-622
16	Nut	1	102571-003	39	Screw	1	110201-001
17	Thread Cutter Lever	1	154577-001	40	Stud Screw	1	155558-001
18	Lever Stopper	1	154578-000	41	Cord Holder	1	140647-001
19	Screw	1	062711-412	42	Washer	1	155559-001
20	Lever Spring	1	154579-001	43	Screw	1	013670-712
21	Shaft	1	154580-001	44	Cap	1	155578-000
22	Shaft Bushing	1	154581-001	45	Washer	1	100645-003
23	Screw	1	151607-001				

H. 押工関係(1)

Presser Foot Mechanism (1)/Stoffdrückerfuß (1)

Mécanisme du pied presseur (1)/Mecanismo del presa telas (1)

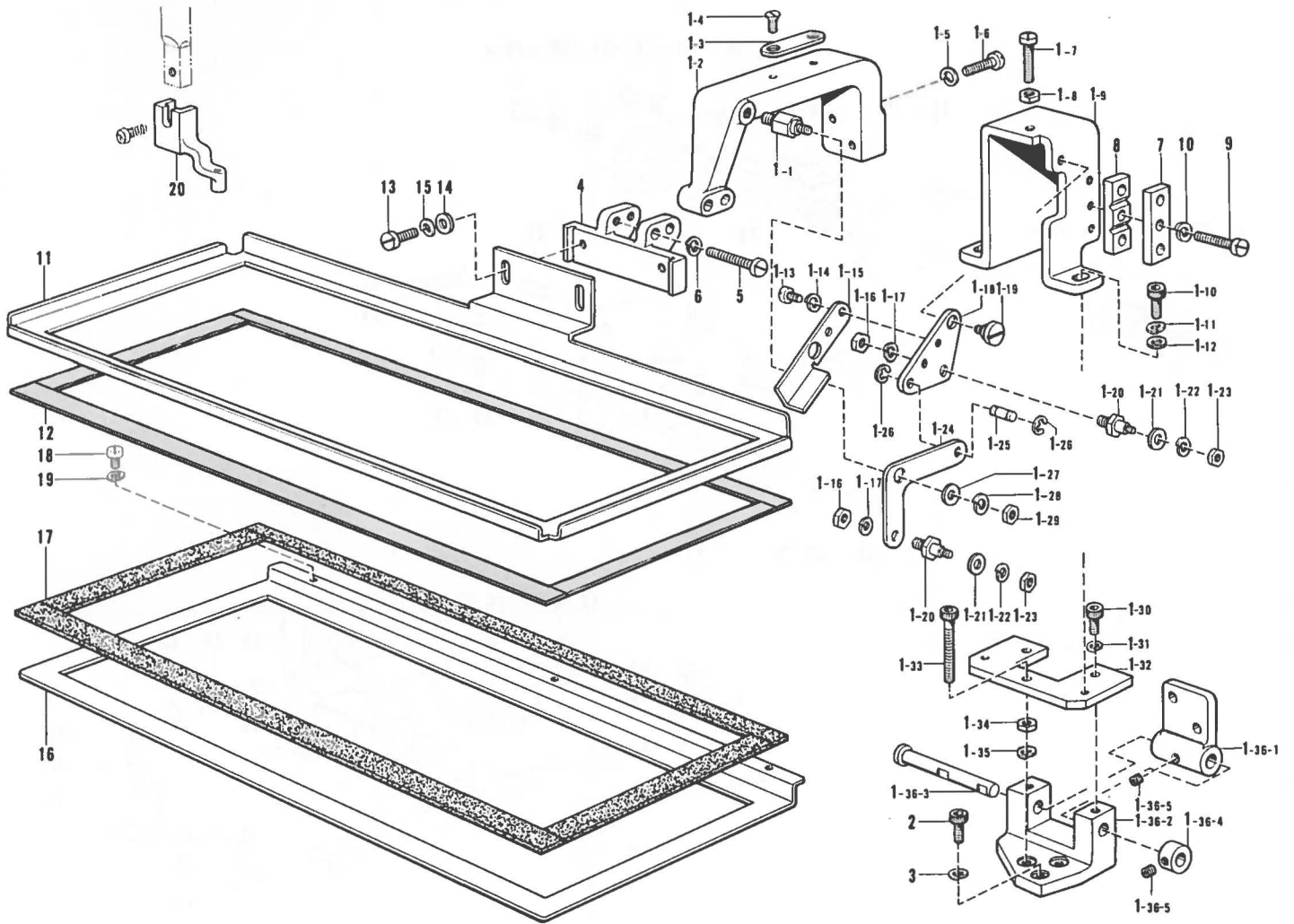

Ref. No.	Name of Parts	Q'ty	Parts No.	Ref. No.	Name of Parts	Q'ty	Parts No.
1	Presser Arm Assembly	1	154131-001	1-31	Spring Washer	2	028040-242
1-1	Lever Shaft(A)	1	152270-001	1-32	Supporter Plate	1	154110-001
1-2	Presser Arm	1	154109-001	1-33	Bolt	1	018403-022
1-3	Stopper Plate	1	154112-001	1-34	Nut	1	021400-202
1-4	Screw	2	003300-812	1-35	Spring Washer	1	028040-242
1-5	Spring Washer	2	028040-242	1-36	Hinge Holder Assembly	1	154132-101
1-6	Screw	2	007401-412	1-36-1	Hinge For Presser Arm	1	
1-7	Screw	1	007402-013	1-36-2	Hinge Holder	1	
1-8	Nut	1	021400-202	1-36-3	Hinge Shaft	1	155066-001
1-9	Presser Lever Holder	1	154111-001	1-36-4	Set Collar	1	155067-001
1-10	Bolt	2	018401-022	1-36-5	Screw	2	014400-522
1-11	Spring Washer	2	028040-242	2	Bolt	2	018401-022
1-12	Washer	2	025040-232	3	Spring Washer	2	028040-242
1-13	Screw	2	007300-613	4	Presser Plate Supporter	1	152274-101
1-14	Spring Washer	2	028030-243	5	Screw	2	007402-513
1-15	Stopper	1	152273-001	6	Spring Washer	2	028040-242
1-16	Nut	2	021400-202	7	Wire Holder Upper(A)	1	152275-001
1-17	Spring Washer	2	028040-242	8	Wire Holder Lower(A)	1	152276-101
1-18	Lever(A)	1	152268-001	9	Screw	3	007402-013
1-19	Screw	1	152269-001	10	Spring Washer	3	028040-242
1-20	Screw	2	152277-001	11	Presser	1	152280-101
1-21	Washer	2	025030-233	12	Presser Plate Cushion	1	152281-000
1-22	Spring Washer	2	028030-243	13	Screw	2	007400-813
1-23	Nut	2	021300-103	14	Washer	2	025040-232
1-24	Lever(B)	1	152271-001	15	Spring Washer	2	028040-242
1-25	Lever Shaft(B)	1	152272-001	16	Feed Plate A	1	152282-101
1-26	Stop Ring	2	048030-342	17	Friction Plate	1	152653-000
1-27	Washer	1	025040-232	18	Screw	3	007300-803
1-28	Spring Washer	1	028040-242	19	Spring Washer	3	028030-243
1-29	Nut	1	021400-202	20	Presser Foot A	1	152283-101
1-30	Bolt	2	018400-822				

H. 押工関係 (2)

Presser Foot Mechanism (2)/Stoffdrückerfuß (2)

Mécanisme du pied presseur (2)/Mecanismo del presa telas (2)

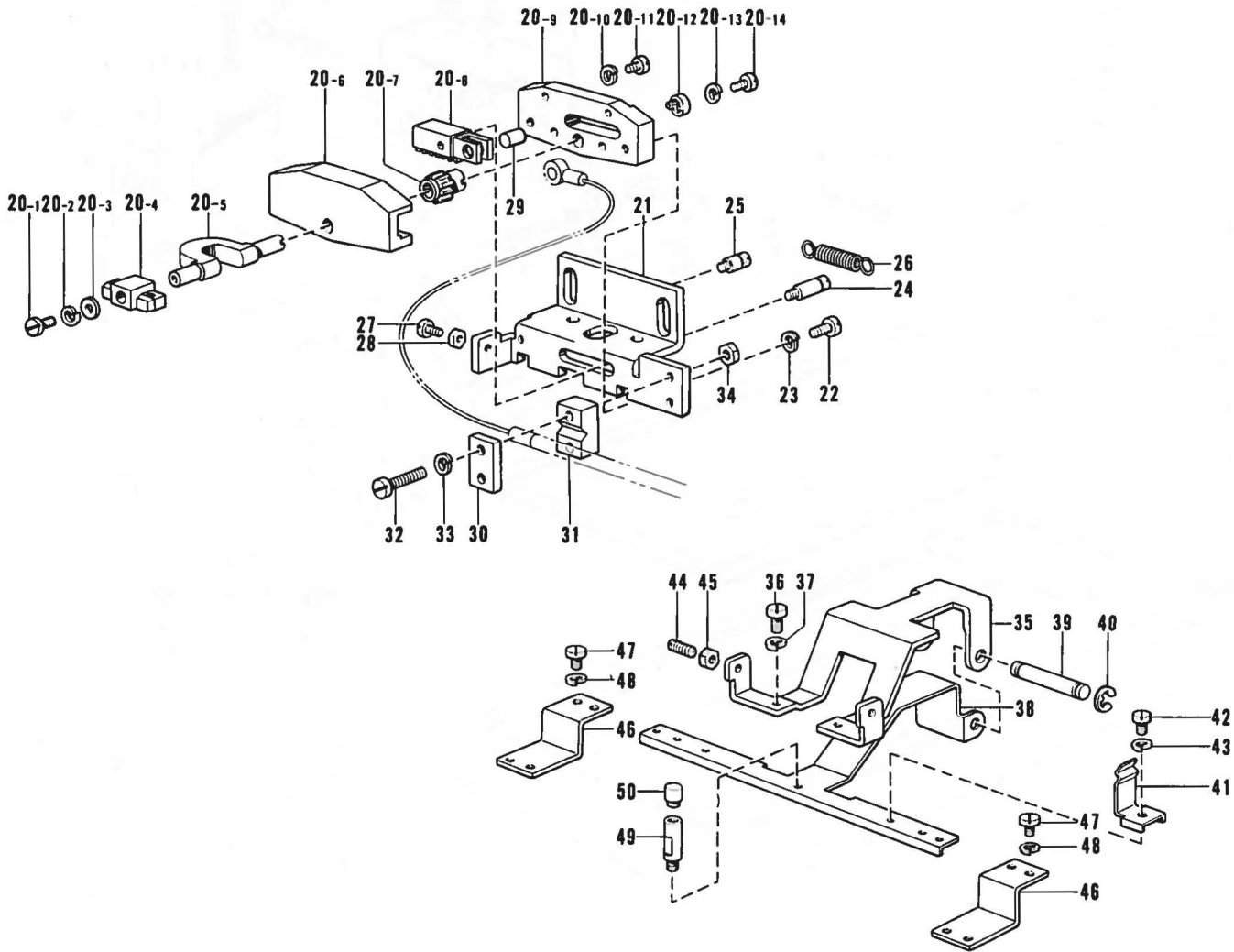

Ref. No.	Name of Parts	Q'ty	Parts No.	Ref. No.	Name of Parts	Q'ty	Parts No.
20	Presser Crank Assembly	1	154133-001	29	Pin	1	154055-001
20-1	Screw	1	007260-613	30	Wire Holder Upper C	1	154056-001
20-2	Spring Washer	1	028260-243	31	Wire Holder Lower C	1	154057-001
20-3	Washer	1	025260-133	32	Screw	2	007402-013
20-4	Presser Plate Holder	1	154044-101	33	Spring Washer	2	028040-242
20-5	Presser Crank	1	—	34	Nut	2	021400-202
20-6	Presser Crank Base	1	—	35	Positioning Base	1	154058-001
20-7	Pinion Gear	1	—	36	Screw	2	007400-813
20-8	Rack Gear	1	—	37	Spring Washer	2	028040-242
20-9	Presser Crank Plate	1	—	38	Positioning Lever	1	154059-001
20-10	Spring Washer	4	028260-242	39	Positioning Lever Shaft	1	154060-001
20-11	Screw	4	007260-612	40	Stop Ring	2	048030-342
20-12	Washer	1	154050-001	41	Positioning Holder Spring	2	154061-001
20-13	Spring Washer	1	028260-243	42	Screw	2	007300-413
20-14	Screw	1	007260-613	43	Spring Washer	2	028030-243
21	Inner Clamp Holder	1	154051-001	44	Screw	2	014400-822
22	Screw	2	007400-813	45	Nut	2	021400-202
23	Spring Washer	2	028040-242	46	Positioning Set Plate	2	154062-001
24	Hook(A)	1	154052-001	47	Screw	4	007300-413
25	Hook(B)	1	154053-001	48	Spring Washer	4	028030-243
26	Spring	1	154054-001	49	Positioning Setter Shaft	1	154065-001
27	Screw	1	007302-013	50	Cap	1	154066-000
28	Nut	1	021300-103				

J. 駆動側送り関係(1)

Feed Guide Mechanism (1)/Transportführung (1)

Mécanisme du guide de l'entraînemt (1)/Mecanismo de la guía de alimentación (1)

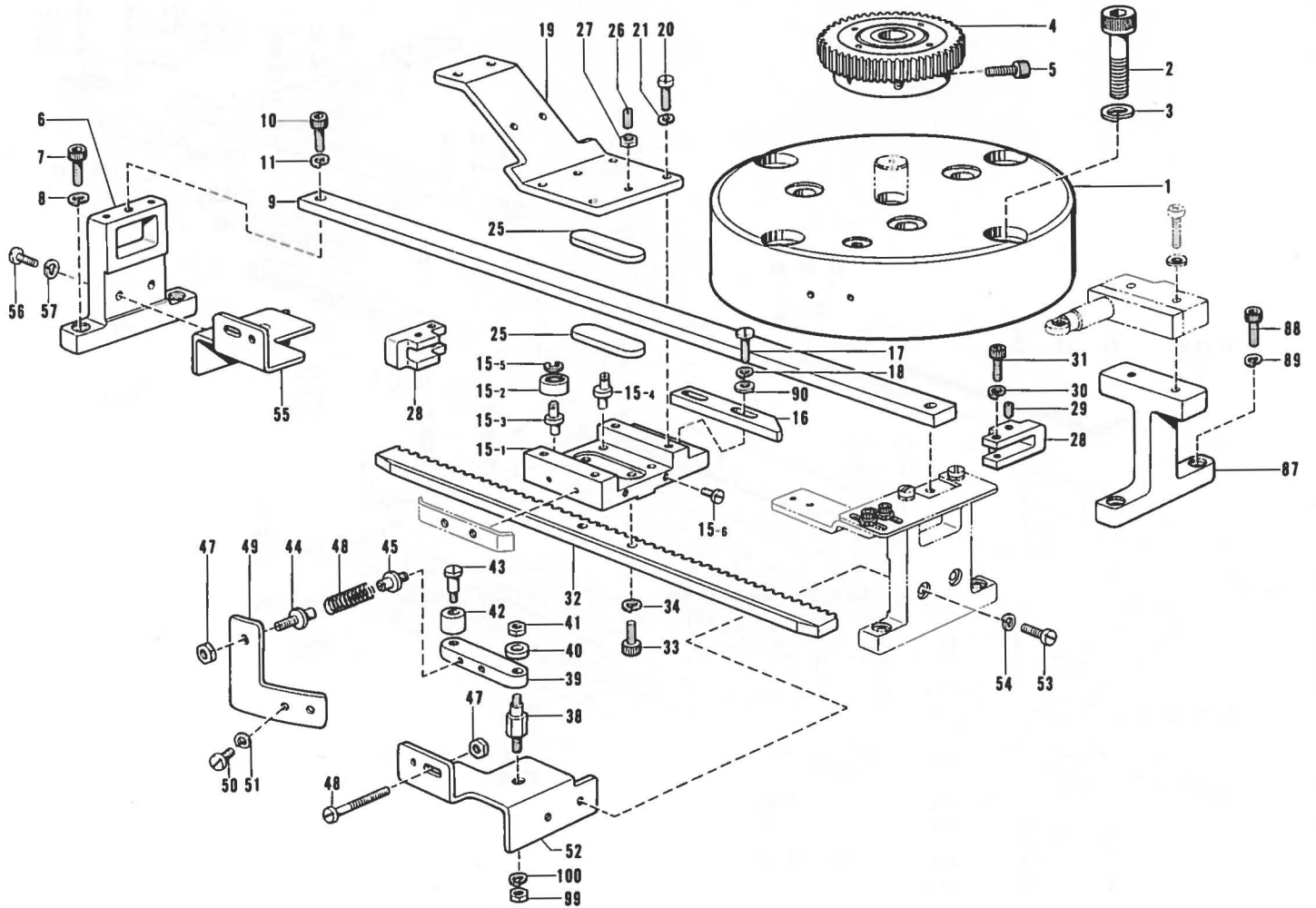

Ref. No	Name of Parts	Q'ty	Parts No.	Ref. No	Name of Parts	Q'ty	Parts No.
1	Motor Bracket	1	モータブラケット	2	Bolt	4	018401-622
2	Bolt	8	アナボルト 10×50	31	Spring Washer	4	028050-242
3	Spring Washer	8	バネザガネ 2-10	32	Rack Gear X	1	152307-000
4	Driving Gear Assembly	2	ギヤクミ	33	Bolt	2	018501-222
5	Bolt	4	アナボルト 5×16	34	Spring Washer	2	028050-242
6	Bracket Guider Base	4	ブラケットアンナイダイ	38	Guide Shaft	4	152309-001
7	Bolt	8	アナボルト 5×16	39	Guide Plate	4	152310-001
8	Spring Washer	8	バネザガネ 2-5	40	Washer	4	152311-001
9	Bracket Guide X	1	ブラケットアンナイ X	41	Nut	4	021400-202
10	Bolt	2	アナボルト M5×12	42	Guide Roller	4	152312-001
11	Spring Washer	2	バネザガネ 2-5	43	Guide Roller Shaft	4	152313-001
15	Bracket Assembly	2	ブラケットクミ	44	Spring Guide A	4	152314-001
15- 1	Bracket	2	ブラケット	45	Spring Guide B	4	152315-001
15- 2	Bearing	8	ベアリング	46	Spring	4	152316-001
15- 3	Roller Shaft A	4	コロジク A	47	Nut	6	021400-202
15- 4	Eccentric Roller Shaft A	4	ヘンシンコロジク A	48	Screw	2	007403-512
15- 5	Stop Ring E	8	トメワ E2	49	Spring Guide Plate M	2	152317-101
15- 6	Screw	8	ヒラネジ 3×8	50	Screw	4	007401-012
16	Zero Positinal Dog	2	ゲンテンドグ	51	Spring Washer	4	028040-242
17	Screw	4	ヒラネジ 4×14	52	Spring Guide Plate R	1	152318-001
18	Spring Washer	4	バネザガネ 2-4	53	Screw	2	007401-412
19	Coupling Plate X	1	ブラケットレンゲツイタ X	54	Spring Washer	2	028040-242
20	Screw	4	ヒラネジ 4×14	55	Spring Guide Plate L	1	152319-001
21	Spring Washer	4	バネザガネ 2-4	56	Screw	2	007401-412
25	Slide Plate A	4	スベリイタ A	57	Spring Washer	2	028040-242
26	Screw	4	アナトメネジ 4クボミ	87	Zero-Position Limit Supporter	2	152337-001
27	Nut	4	ナット 2 シュ 4	88	Bolt	4	018501-622
28	Bracket Stopper A	4	ブラケットストッパー A	89	Spring Washer	4	028050-242
29	Screw	4	アナトメネジ 4×5クボミ	90	Washer	4	025040-232
30	Spring Washer	4	バネザガネ 2-4	99	Nut	2	021060-102
				100	Spring Washer	2	028060-242

J. 駆動側送り関係 (2)

Feed Guide Mechanism (2)/Transportführung (2)

Mécanisme du guide de l'entraînement (2)/Mecanismo de la guía de alimentación (2)

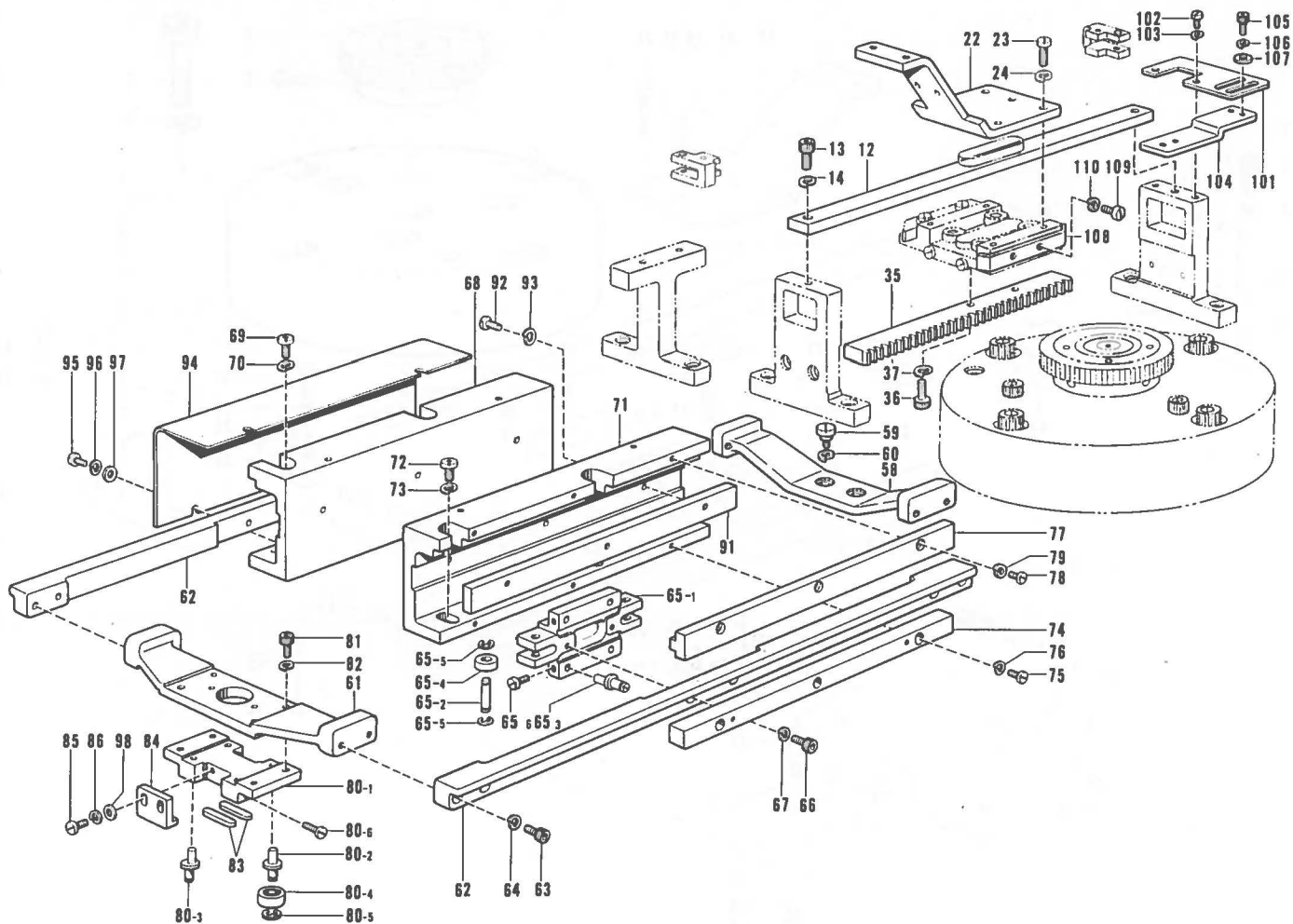

Ref. No.	Name of Parts	Q'ty	Parts No.	Ref. No.	Name of Parts	Q'ty	Parts No.
12	Bracket Guide Y	1	152297-001	77	Roller Guide Upper	2	154013-001
13	Bolt	2	018501-222	78	Screw	6	007301-012
14	Spring Washer	2	028050-242	79	Spring Washer	6	028030-242
22	Coupling Plate Y	1	152304-101	80	Feed Guide Base Assembly	1	152673-001
23	Screw	4	007401-413	80-1	Feed Guide Base	1	
24	Spring Washer	4	028040-242	80-2	Roller Shaft B	2	152333-001
35	Rack Gear Y	1	152308-200	80-3	Eccentric Roller Shaft B	2	152334-001
36	Bolt	2	018501-222	80-4	Bearing	4	152299-000
37	Spring Washer	2	028050-242	80-5	Stop Ring	4	048020-342
58	Guide Base Holder(R)	1	152320-001	80-6	Screw	4	007300-613
59	Screw	2	154113-001	81	Bolt	4	018401-022
60	Spring Washer	2	028060-242	82	Spring Washer	4	028040-242
61	Guide Base Holder(F)	1	152322-001	83	Slide Plate B	2	152335-000
62	Feed Coupling Plate	2	154015-001	84	Guide Plate For Feed Guide Base	2	152336-001
63	Bolt	8	018401-222	85	Screw	4	007301-012
64	Spring Washer	8	028040-242	86	Spring Washer	4	028030-242
65	Roller Shaft Holder A Assembly	2	154008-001	91	Roller Guide Side	2	152648-001
65-1	Roller Shaft Holder A	2		92	Screw	6	007301-012
65-2	Roller Shaft C	4	152642-001	93	Spring Washer	6	028030-242
65-3	Eccentric Roller Shaft C	8	152326-001	94	Cover	2	154014-001
65-4	Bearing Roller	12	152327-000	95	Screw	8	007300-612
65-5	Stop Ring	16	048040-342	96	Spring Washer	8	028030-242
65-6	Screw	8	007300-612	97	Washer	8	025030-232
66	Bolt	4	018401-222	98	Washer	4	025030-232
67	Spring Washer	4	028040-242	101	Limit Plate C	4	155058-001
68	Roller Guide Base (L)	1	154010-001	102	Screw	8	007400-812
69	Screw	2	062681-012	103	Spring Washer	8	028040-242
70	Spring Washer	2	028680-242	104	Limit Set Plate	4	155059-001
71	Roller Guide Base (R)	1	154011-001	105	Bolt	8	018300-822
72	Screw	2	062681-012	106	Spring Washer	8	028030-242
73	Spring Washer	2	028680-242	107	Washer	8	025030-232
74	Roller Guide Lower	2	154012-001	108	Over Limit Dog	2	155060-001
75	Screw	6	007301-012	109	Screw	4	007300-803
76	Spring Washer	6	028030-242	110	Spring Washer	4	028030-243

K. 送り案内関係

Feed Guide Mechanism / Transportführung

Mécanisme du guide de l'entraînement / Mecanismo de la guía de alimentación

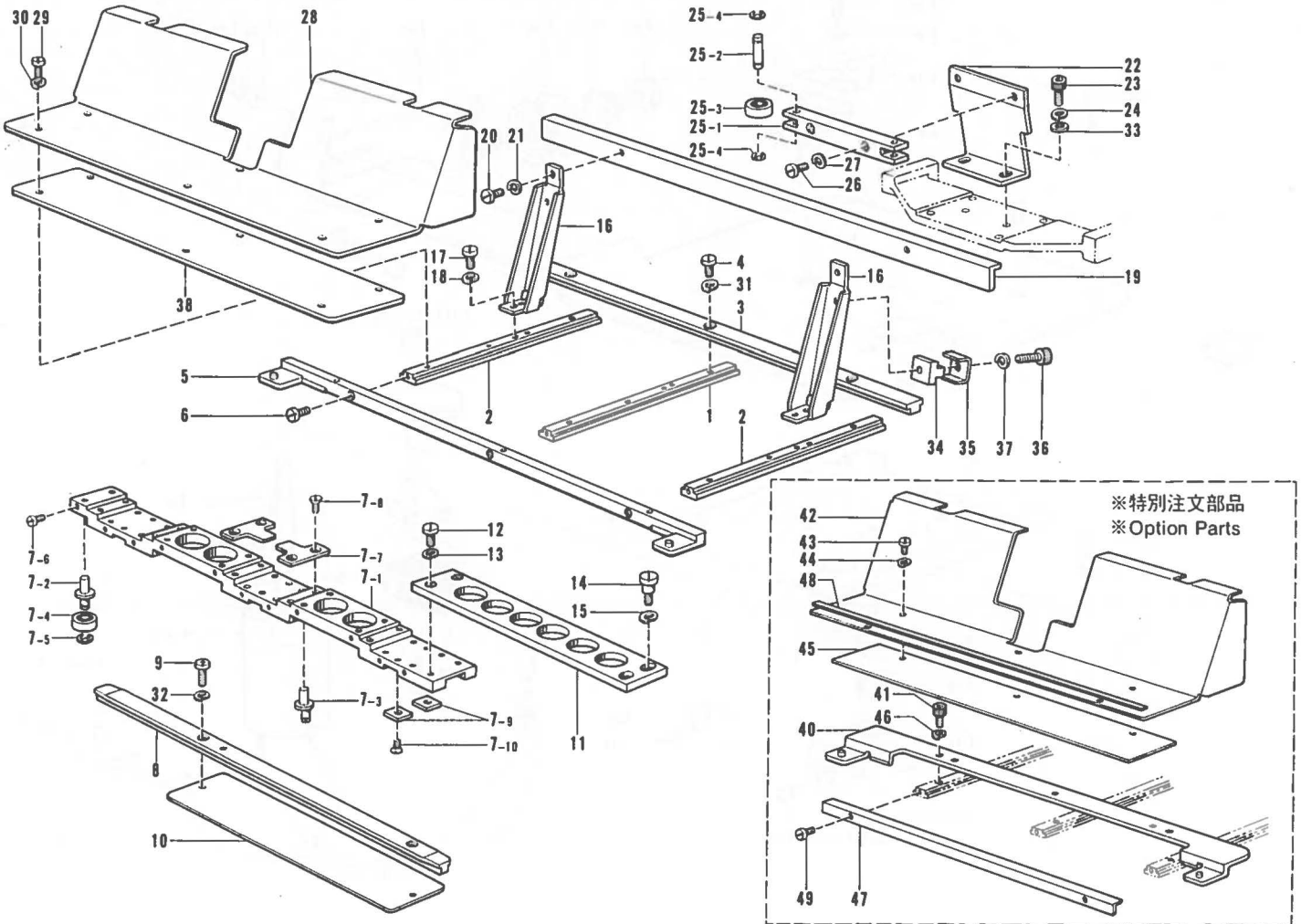

Ref. No	Name of Parts	Q'ty	Parts No	Ref. No.	Name of Parts	Q'ty	Parts No.
1	Feed Guide Y-A	1	152338-001	22	Roller Shaft Holder Supporter	1	152351-101
2	Feed Guide Y-B	2	152339-001	23	Bolt	2	018401-022
3	Feed Guide X	1	152340-101	24	Spring Washer	2	028040-242
4	Screw	3	007400-812	25	Roller Shaft Holder B Assembly	1	152671-001
5	Front Plate A	1	152342-101	25-1	Roller Shaft Guide	1	_____
6	Screw	3	154070-001	25-2	Roller Shaft D	2	152353-001
7	Slider Assembly	1	152670-001	25-3	Bearing	2	152299-000
7-1	Slider	1	_____	25-4	Stop Ring	4	048020-342
7-2	Roller Shaft B	2	152333-001	26	Screw	2	007400-812
7-3	Eccentric Roller Shaft B	20	152334-001	27	Spring Washer	2	028040-242
7-4	Bearing	22	152299-000	28	Feed Cover Assembly(A)	1	155073-001
7-5	Stop Ring	22	048020-342	29	Screw	6	007400-613
7-6	Screw	22	007300-412	30	Spring Washer	6	028040-242
7-7	Slider Guide A	5	152344-001	31	Spring Washer	3	028040-242
7-8	Screw	10	003300-604	32	Spring Washer	2	028350-242
7-9	Slider Guide B	6	152345-001	33	Washer	2	025040-232
7-10	Screw	6	003300-604	34	Wire Holder A	1	152643-001
8	Base Plate For Feed Guide	1	152346-101	35	Wire Holder B	1	152644-001
9	Screw	2	007671-212	36	Bolt	1	018401-622
10	Plate	1	157510-000	37	Spring Washer	1	028040-242
11	Slider Coupling Plate	1	152348-001	38	Lower Plate Feed Cover	1	154023-000
12	Screw	2	007400-813	40	Front Plate B	1	154098-001
13	Spring Washer	2	028040-242	41	Bolt	3	018400-822
14	Screw	2	154113-001	42	Feed Cover Assembly(B)	1	155074-001
15	Spring Washer	2	128060-242	43	Screw	3	007400-613
16	Support Guide Holder	2	152349-101	44	Spring Washer	3	028040-242
17	Screw	4	007400-813	45	Lower Plate Feed B	1	154100-000
18	Spring Washer	4	028040-242	46	Spring Washer	3	028040-242
19	Feed Support Guide	1	152350-101	47	Slider Cover	1	154101-101
20	Screw	2	007400-813	48	Cushion	1	154102-000
21	Spring Washer	2	028040-242	49	Screw	2	007300-613

L. 糸巻装置

Bobbin Winder Mechanism / Spuler

Mécanisme du bobineur / Mecanismo del del devandor de la canilla

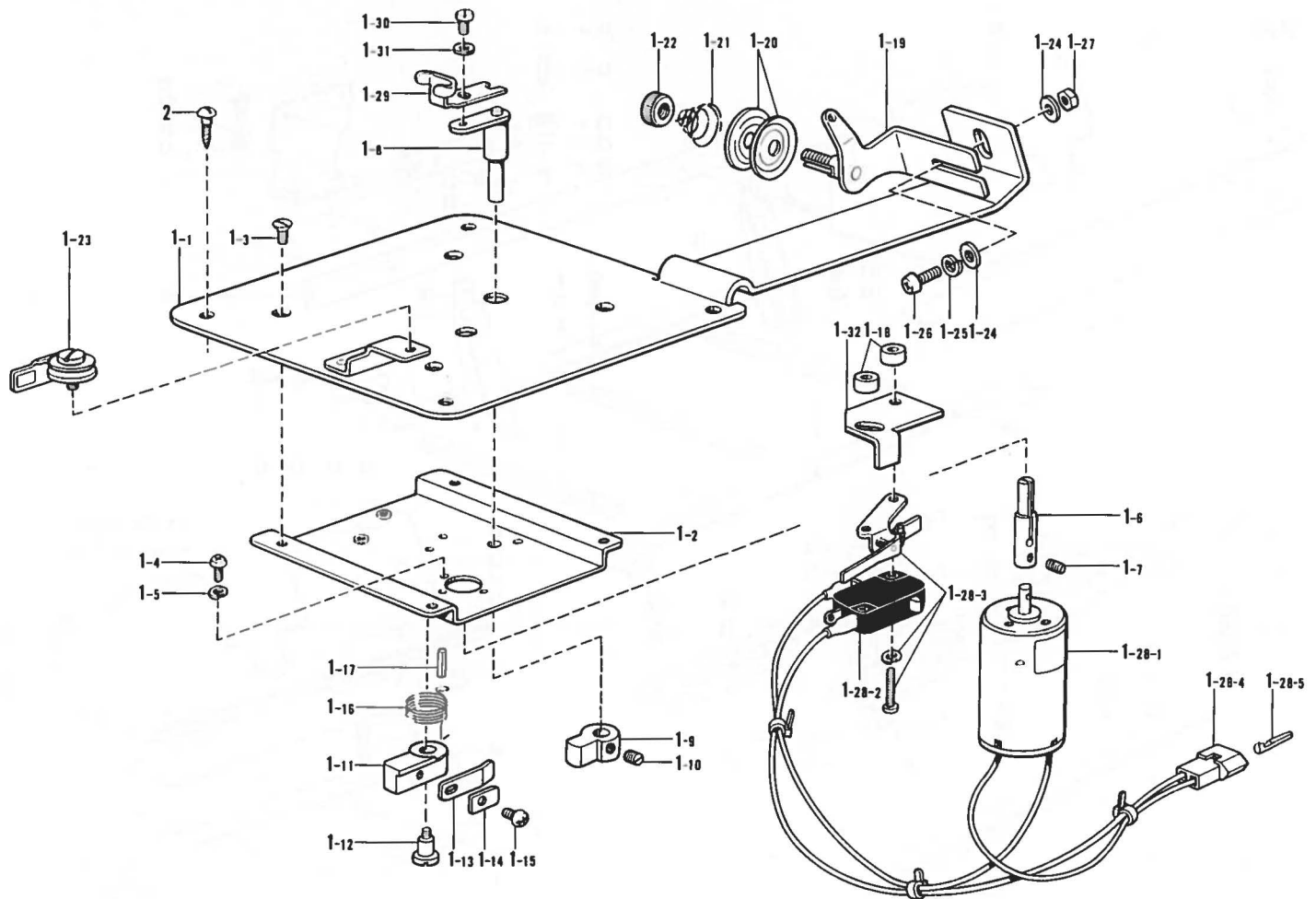

Ref. No.	Name of Parts	Q'ty	Parts No.	Ref. No.	Name of Parts	Q'ty	Parts No.
1	Bobbin Winder Assembly	1	152651-201	1-20	Tension Disc	2	145446-001
1-1	Bobbin Winder Wheel Bracket	1	—————	1-21	Tension Spring	1	100401-001
1-2	Motor Setting Plate	1	—————	1-22	Nut	1	100136-001
1-3	Screw	4	004300-513	1-23	Thread Trimmer Assembly	1	146197-001
1-4	Screw	3	002300-603	1-24	Washer	2	025040-233
1-5	Spring Washer	3	028030-242	1-25	Spring Washer	1	028040-243
1-6	Bobbin Winder	1	152358-001	1-26	Screw	1	002401-103
1-7	Screw	2	014300-322	1-27	Nut	1	021401-003
1-8	Bobbin Holder Arm	1	154024-001	1-28	Bobbin Winder Motor Assembly	1	152505-001
1-9	Bobbin Winder Claw	1	154092-001	1-28-1	Motor	1	152506-000
1-10	Screw	2	013680-512	1-28-2	Micro Switch	1	—————
1-11	Lever	1	152361-001	1-28-3	Micro Actuator	1	—————
1-12	Screw	1	152362-001	1-28-4	Nylon Connector	1	—————
1-13	Spring	1	111942-001	1-28-5	Terminal pin	2	552851-001
1-14	Washer	1	111943-001	1-29	Bobbin Presser Plate	1	152645-001
1-15	Screw	1	060660-512	1-30	Screw	1	007300-613
1-16	Spring	1	152363-001	1-31	Washer	1	025030-233
1-17	Spring Pin	1	—————	1-32	Slopper	1	158597-001
1-18	Collar	2	152364-001	2	Screw	5	032311-306
1-19	Bobbin Winder Guide Bracket Assembly	1	145571-101				

M. 電装品関係 (1)

Power Supply Equipment Mechanism (1)/Stromversorgung (1)

Mécanisme de l'équipement en alimentation électrique (1)/Mecanismo de la equipo de alimentación de corriente (1)

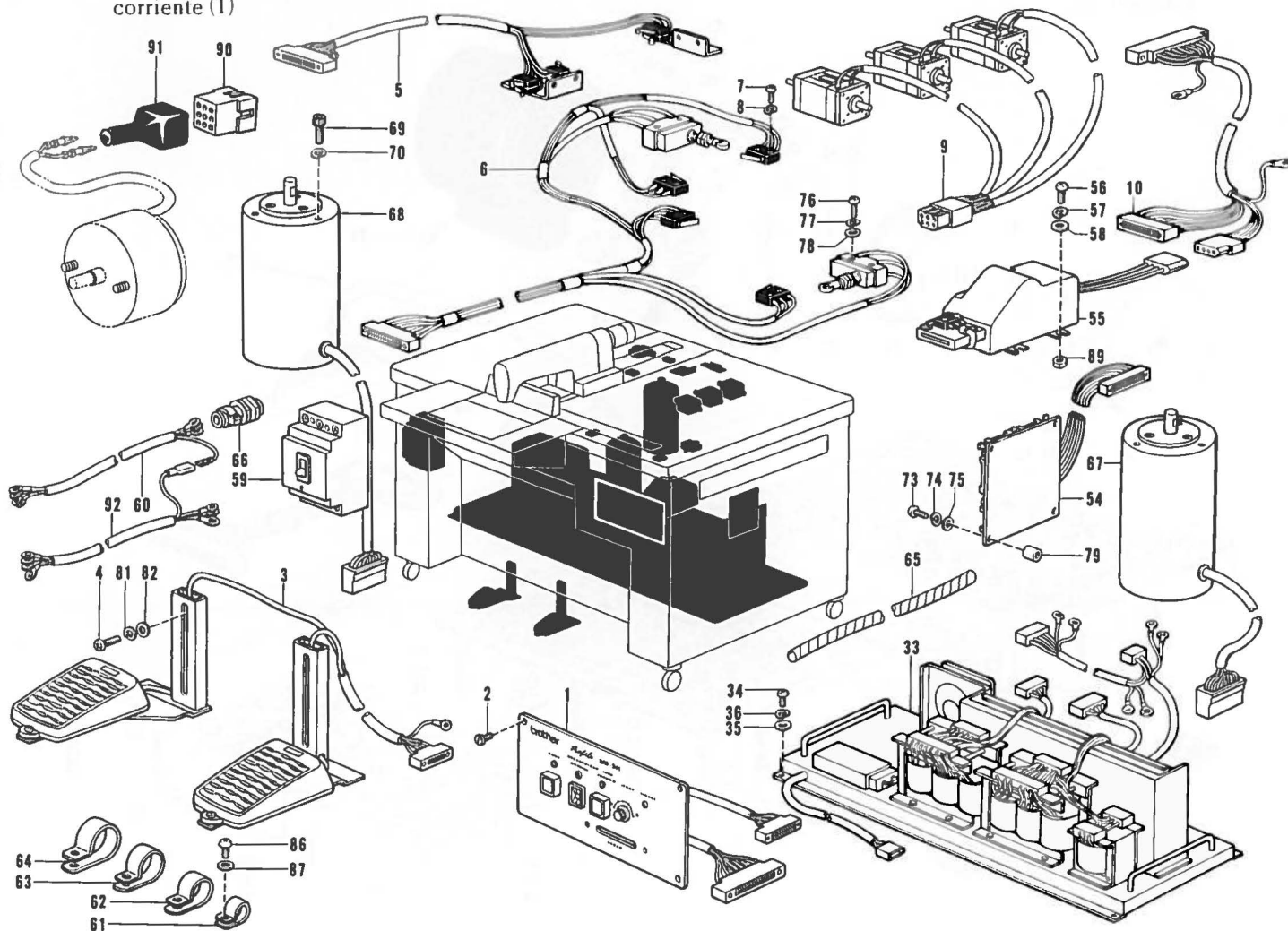

Ref. No.	Name of Parts	Q'ty	Parts No.	Ref. No.	Name of Parts	Q'ty	Parts No.
1	Switch Board Assembly B-2	1	554482-000	63	Cord Holder	3	554482-000
2	Screw	3	007400-812	64	Cord Holder	4	552908-000
3	Foot Switch Assembly	1	152433-101	65	Tube B	1	152504-000
4	Screw	2	002402-512	66	Cord Bushing	1	152510-000
5	Synchronizer Switch Assembly	1	152437-200	67	Motor Assembly X	1	155001-001
6	Micro Switch Assembly	1	152440-101	68	Motor Assembly Y	1	155033-001
7	Screw	8	001021-016	69	Bolt	6	018082-022
8	Spring Washer	8	028020-243	70	Spring Washer	6	028080-242
9	Clamp Motor Assembly	1	152444-101	73	Screw	4	002301-605
10	Reader Harness Assembly	1	152446-101	74	Spring Washer	4	028030-243
33	Power Supply Equip Assembly	1		75	Washer	4	025030-233
34	Screw	6	002401-003	76	Screw	4	002402-512
35	Washer	6	025040-232	77	Spring Washer	4	028040-242
36	Spring Washer	6	028040-242	78	Washer	4	025040-232
54	Extension Board	1	152499-101	79	Spacer A	4	152544-000
55	Card Reader	1	152500-000	81	Spring Washer	2	028040-242
56	Screw	4	002401-003	82	Washer	2	025040-232
57	Spring Washer	4	028040-242	86	Screw	14	002401-003
58	Washer	4	025040-232	87	Washer	14	025040-233
59	Fuse Breaker B	1		89	Nut	4	021400-202
60	Cable Assembly A	1	S01937-001	90	Nylon Connector	1	145681-000
61	Cord Holder	9	525664-000	91	Cap	1	145596-001
62	Cord Holder	2	525907-000	92	Cable Assembly B	1	154136-001

M. 電装品関係 (2)

Power Supply Equipment Mechanism (2)/Stromversorgung (2)

Mécanisme de l'équipement en alimentation électrique (2)/Mecanismo de la equipo de alimentación de corriente (2)

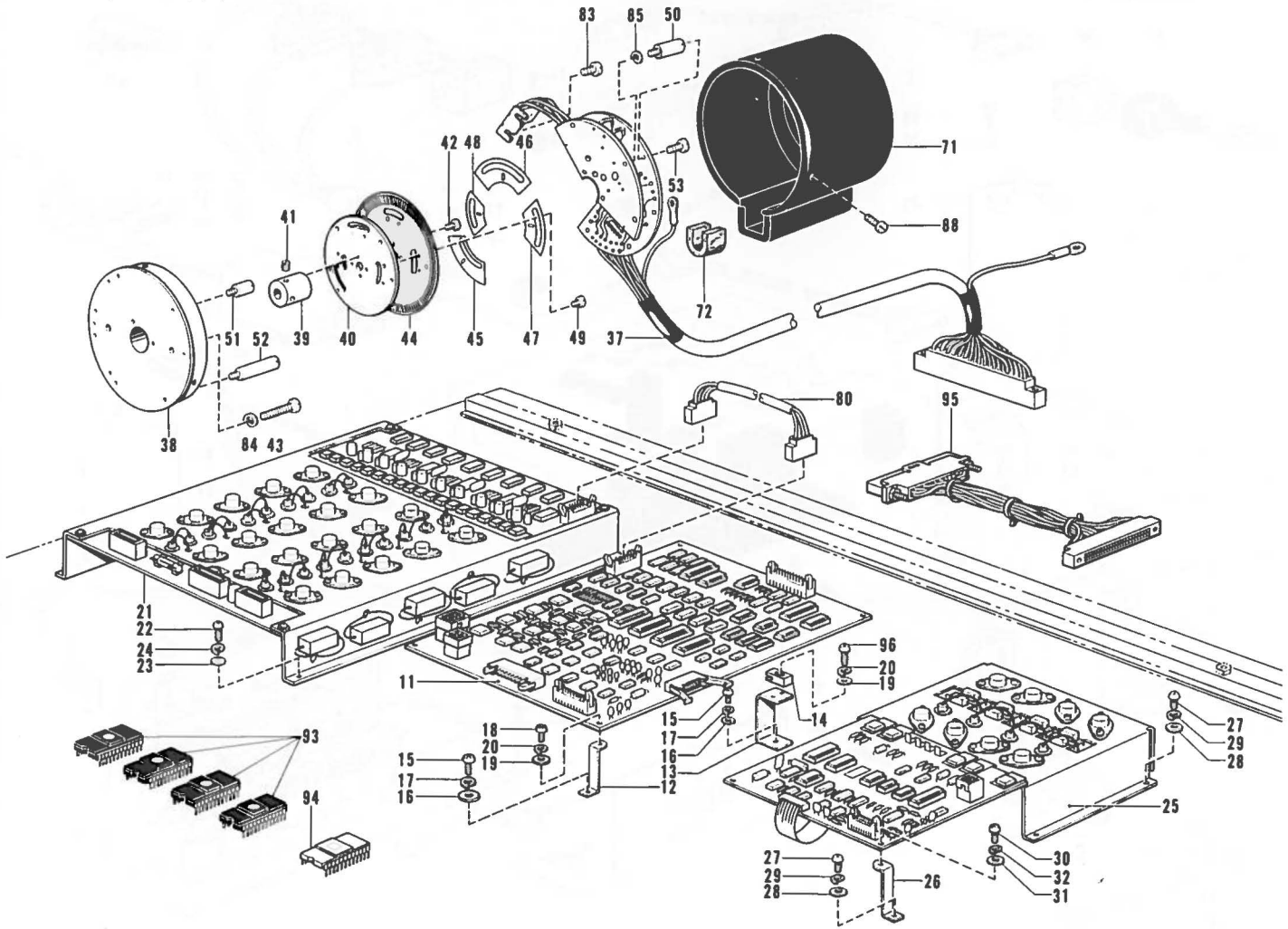

Ref. No.	Name of Parts	Q'ty	Parts No.	Ref. No.	Name of Parts	Q'ty	Parts No.
11	Printed Circuit Board Assembly	1	152451-100	40	Encoder Setting Plate	1	157511-001
12	Circuit Board Supporter	4	152452-001	41	Screw	2	014400-522
13	Circuit Board Supporter	2	152453-001	42	Screw	4	002300-603
14	Fixing Plate	2	152454-100	43	Screw	2	007402-013
15	Screw	6	002401-003	44	Encoder Slit	1	157512-000
16	Washer	6	025040-232	45	Mask A	1	152491-000
17	Spring Washer	6	028040-242	46	Mask B-2	1	157513-000
18	Screw	4	002300-803	47	Mask C	1	152493-000
19	Washer	6	025030-233	48	Mask D-2	1	157514-000
20	Spring Washer	6	028030-243	49	Screw	9	007260-313
21	PMO Circuit Board	1	152461-001	50	Set Shaft A	3	152496-001
22	Screw	4	002401-003	51	Set Shaft B	5	152497-001
23	Washer	4	025040-232	52	Set Shaft C	2	152498-001
24	Spring Washer	4	028040-242	53	Screw	7	002300-803
25	DD-PROM	1	152463-101	71	Encoder Cover	1	152513-101
26	Circuit Board Supporter	2	152452-001	72	Felt	1	152516-100
27	Screw	6	002401-003	80	Clock Harness Assembly	1	154036-000
28	Washer	6	025040-232	83	Screw	2	002300-803
29	Spring Washer	6	028040-242	84	Spring Washer	2	028040-242
30	Screw	2	002300-803	85	Spring Washer	3	028030-243
31	Washer	2	025030-233	88	Screw	3	007401-012
32	Spring Washer	2	028030-243	93	CNT-PROM Assembly H	1	154139-000
37	Encoder Assembly	1	152480-000	94	DD PROM-H-180	1	154144-000
38	Encoder Setting Base	1	152487-201	95	Programmer Harness Assembly A	1	152556-100
39	Encoder Shaft	1	152488-001	96	Screw	2	002301-605

N. 押エアクチュエータ関係
 Actuator Mechanism/Stoffdrückerbetätigung
 Mécanisme de l'actuateur/Mecanismo del impulsor

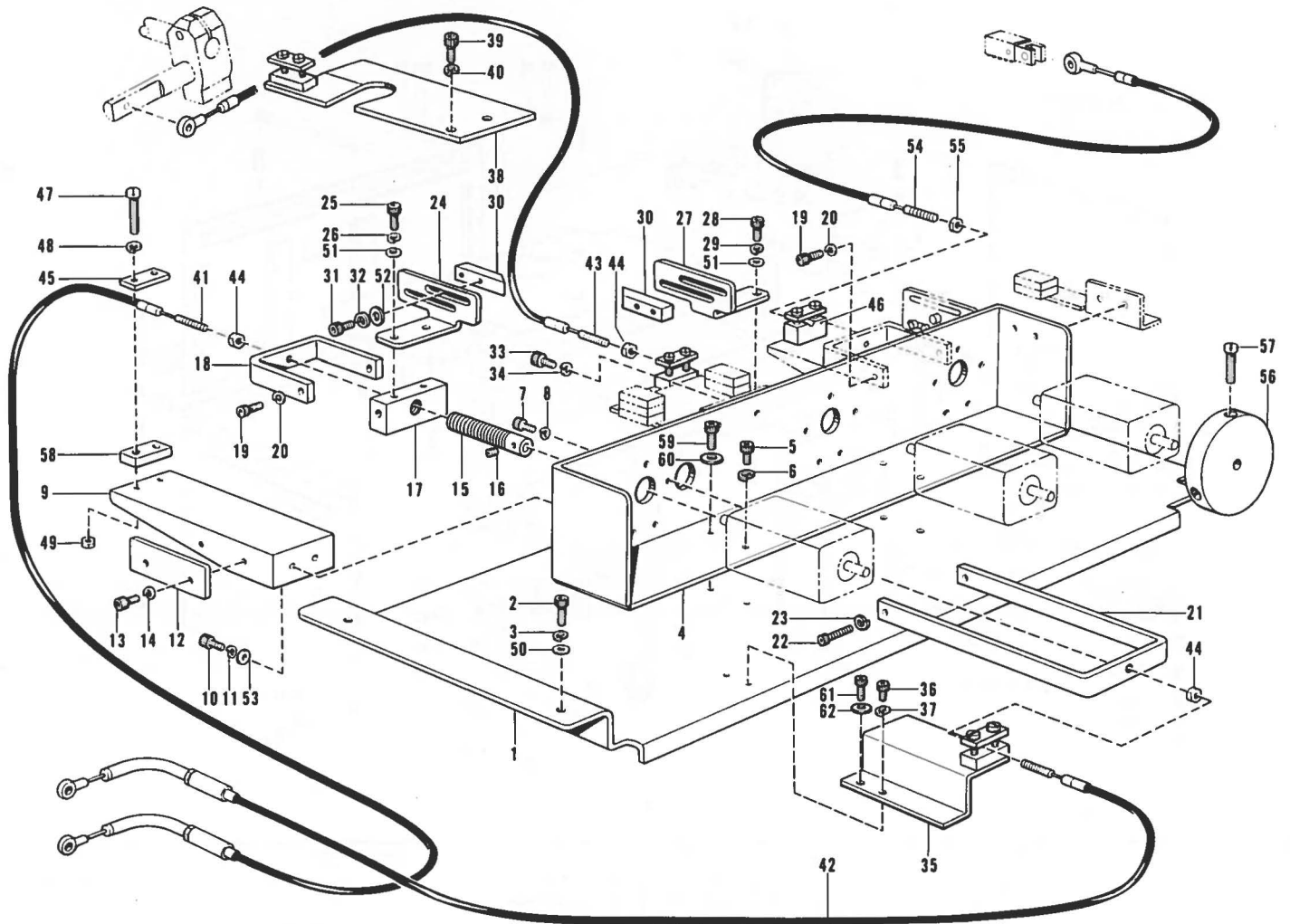

Ref. No.	Name of Parts	Q'ty	Parts No.	Ref. No.	Name of Parts	Q'ty	Parts No.
1	Actuator Base	1	152365-101	32	Spring Washer	12	028030-242
2	Bolt	4	018501-222	33	Bolt	4	018400-822
3	Spring Washer	4	028050-242	34	Spring Washer	4	028040-242
4	Motor Supporter	1	152366-101	35	Wire Holder Base	1	152640-001
5	Bolt	3	018400-822	36	Bolt	1	018400-822
6	Spring Washer	3	028040-242	37	Spring Washer	1	028040-242
7	Bolt	9	018300-822	38	Wire Holder Plate	1	154114-101
8	Spring Washer	9	028030-242	39	Bolt	2	018501-222
9	Block Guide Base	3	154018-101	40	Spring Washer	2	028050-242
10	Bolt	6	018400-822	41	Wire A	1	155075-001
11	Spring Washer	6	028040-242	42	Wire B	1	155076-001
12	Block Guide Plate	3	152368-001	43	Wire C	1	155070-001
13	Bolt	6	018400-822	44	Nut	3	021400-202
14	Spring Washer	6	028040-242	45	Wire Holder Upper B	5	152381-101
15	Screw	3	152369-001	46	Wire Holder Lower B	1	152382-101
16	Screw	6	014400-522	47	Screw	10	007402-512
17	Wire Driving Block	3	152370-000	48	Spring Washer	10	028040-242
18	Wire Driving Plate A	3	152371-001	49	Nut	10	021400-202
19	Bolt	4	018401-222	50	Washer	4	025050-232
20	Spring Washer	4	028040-242	51	Washer	6	025040-232
21	Wire Driving Plate B	1	152372-001	52	Washer	12	025030-232
22	Bolt	2	018401-622	53	Washer	6	025040-232
23	Spring Washer	2	028040-242	54	Wire D	1	154067-001
24	Dog Plate A	2	154124-001	55	Nut	1	021400-202
25	Bolt	4	018401-022	56	Pulley	1	154090-001
26	Spring Washer	4	028040-242	57	Screw	2	007301-212
27	Dog Supporting Plate B	1	152374-001	58	Wire Holder Lower D	4	155071-001
28	Bolt	2	018401-022	59	Bolt	1	018401-022
29	Spring Washer	2	028040-242	60	Washer	1	025040-232
30	Dog	6	152375-001	61	Bolt	1	018401-022
31	Bolt	12	018300-822	62	Washer	1	025040-232

P. 動力台関係 (1)

Power Table (1)/Motorgestell (1)

Mécanisme du plateau de la machine (1)/Mecanismo del mesa de la máquina (1)

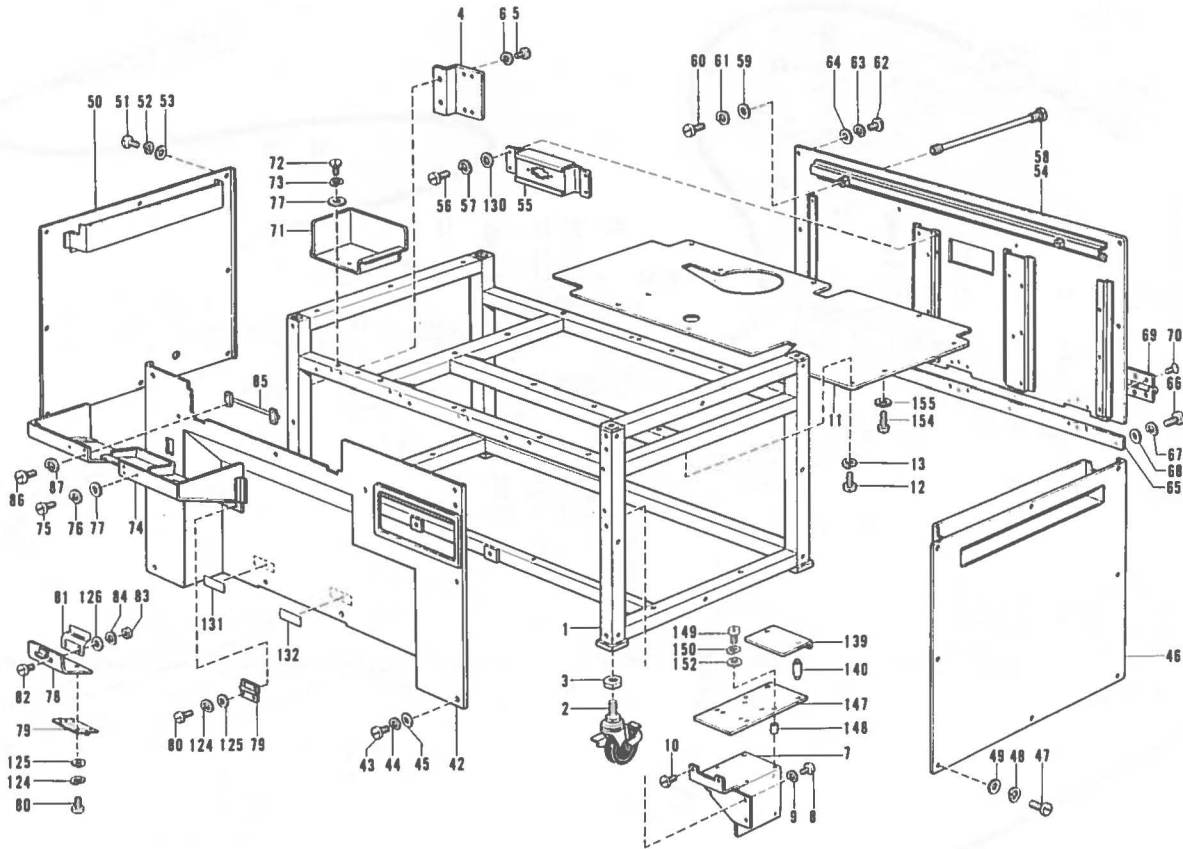

Ref. No.	Name of Parts	Q'ty	Parts No.	Ref. No.	Name of Parts	Q'ty	Parts No.
1	Stand	1	154016-001	66	Screw	2	007400-813
2	Caster	4	152393-000	67	Spring Washer	2	028040-242
3	Nut	4	021160-303	68	Washer	2	025040-232
4	Block Guide Plate B	1		69	Hinge	3	152575-000
5	Screw	2	007401-012	70	Screw	18	003400-804
6	Spring Washer	2	028040-242	71	Table Cover	1	152420-001
7	Card Reader Setting Base	1	152395-101	72	Screw	2	007400-812
8	Screw	2	002401-003	73	Spring Washer	2	028040-242
9	Spring Washer	2	028040-242	74	Rotary Hock Cover Assembly	1	155079-001
10	Screw	2	007300-612	75	Screw	4	007400-813
11	Cover	1	152396-100	76	Spring Washer	4	028040-242
12	Screw	10	002400-502	77	Washer	4	025040-232
13	Spring Washer	10	028040-242	78	Rotary Hock Cover	1	152422-001
42	Front Cover	1	154017-101	79	Hock Cover Hinge	3	152423-000
43	Screw	10	007400-813	80	Screw	12	007300-613
44	Spring Washer	10	028040-242	81	Plate Spring	1	152424-001
45	Washer	10	025040-232	82	Screw	2	007300-803
46	Side Cover Right	1	152408-001	83	Nut	2	021300-103
47	Screw	8	007400-813	84	Spring Washer	2	028030-243
48	Spring Washer	8	028040-242	85	Cover Stopper	1	152425-001
49	Washer	8	025040-232	86	Screw	4	007401-413
50	Side Cover Left	1	152409-001	87	Spring Washer	4	028040-242
51	Screw	8	007400-813	124	Spring Washer	12	028030-243
52	Spring Washer	8	028040-242	125	Washer	12	025030-233
53	Washer	8	025040-232	126	Washer	2	025030-233
54	Rear Cover Assembly	1	152410-101	130	Washer	4	025040-232
55	Connector Setting Plate	1		131	Label	1	
56	Screw	4	007400-613	132	Label	1	
57	Spring Washer	4	028040-242	139	Card Reader Plate	1	154033-000
58	Screw	2	155078-001	140	Supporter	2	157216-001
59	Washer	2	116662-003	147	Card Reader Setting Plate	1	154097-000
60	Screw	2	007400-812	148	Spacer A	4	152544-000
61	Spring Washer	2	028040-242	149	Screw	4	007302-013
62	Screw	6	007400-813	150	Spring Washer	4	028030-243
63	Spring Washer	6	028040-242	152	Washer	2	025040-232
64	Washer	6	025040-232	154	Screw	1	002401-003
65	Rear Cover Plate	1	152419-001	155	Washer	1	025040-233

P. 動力台関係 (2)

Power Table (2)/Motorgestell (2)

Mécanisme du plateau de la machine (2)/Mecanismo del mesa de la máquina (2)

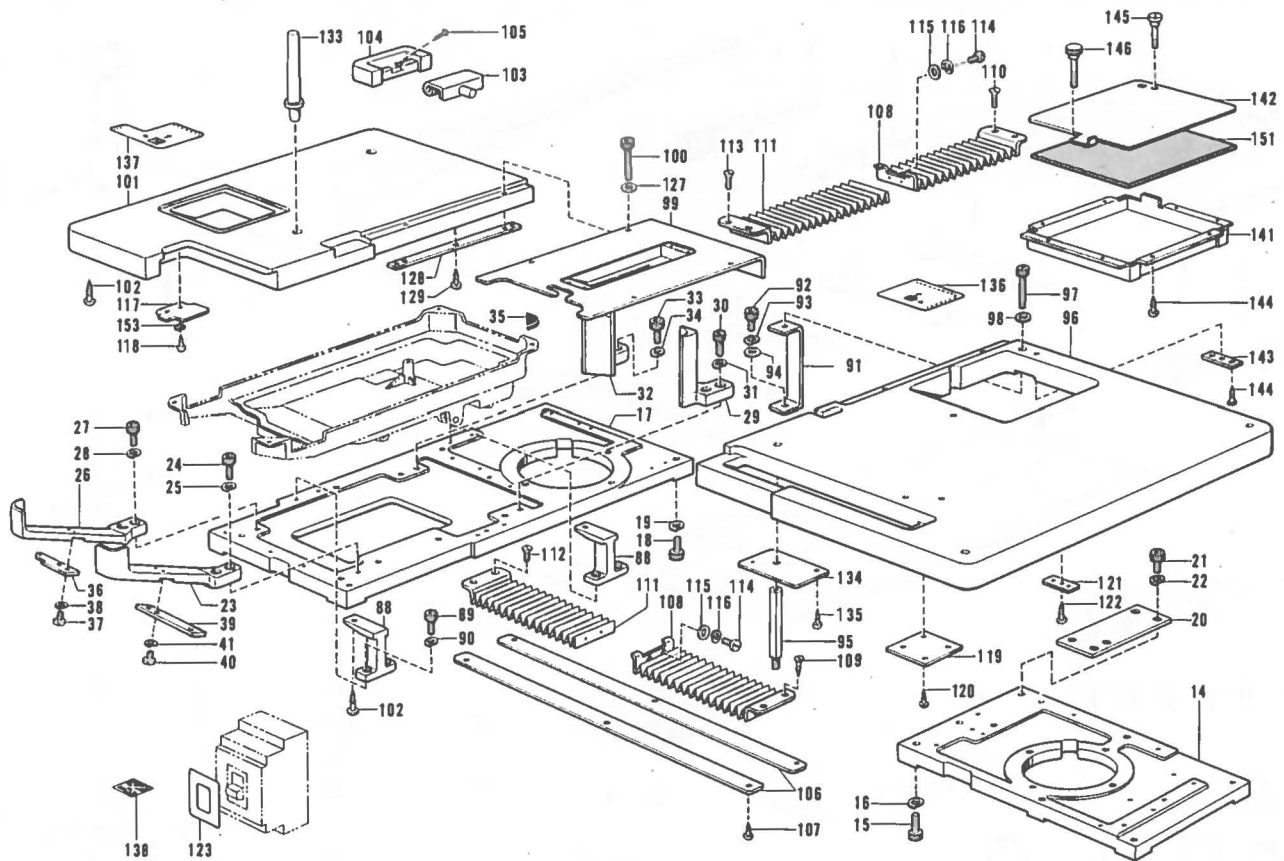

Ref. No.	Name of Parts	Q'ty	Parts No.	Ref. No.	Name of Parts	Q'ty	Parts No.
14	Base A	1	152397-101	101	Table(Light)	1	154020-000
15	Bolt	6	018102-022	102	Screw	5	032452-502
16	Spring Washer	6	028100-242	103	Head Hinge	1	143882-001
17	Base B	1	152646-101	104	Rubber Hinge	1	143910-001
18	Bolt	6	018102-022	105	Nail	2	109714-000
19	Spring Washer	6	028100-242	106	Bellow Plate	2	152579-101
20	Base Coupling Plate	1	155053-001	107	Screw	6	032311-302
21	Bolt	4	018102-022	108	Bellow A	2	152580-001
22	Spring Washer	4	028100-242	109	Screw	2	034311-302
23	Arm Bed Supporter FR	1	152400-101	110	Screw	2	003300-812
24	Bolt	2	018103-022	111	Bellow B	2	152581-001
25	Spring Washer	2	028100-242	112	Screw	2	034311-302
26	Arm Bed Supporter FL	1	152401-101	113	Screw	2	003300-812
27	Bolt	2	018103-022	114	Screw	4	007301-212
28	Spring Washer	2	028100-242	115	Washer	4	025030-232
29	Arm Bed Supporter BR	1	152402-001	116	Spring Washer	4	028030-242
30	Bolt	2	018103-022	117	Table Left Cover	1	155068-001
31	Spring Washer	2	028100-242	118	Screw	2	032311-302
32	Arm Bed Supporter BL	1	152403-001	119	Hinge Fixing Plate	1	152591-001
33	Bolt	2	018103-022	120	Screw	2	032311-302
34	Spring Washer	2	028100-242	121	Stopper Fixing Plate	1	152592-001
35	Cushion	4	152404-000	122	Screw	2	032311-302
36	Hock Cover Supporting Plate A	1	152405-101	123		1	152649-001
37	Screw	2	007401-012	127	Washer	4	025040-232
38	Spring Washer	2	028040-242	128	Table(C) Supporting Plate	2	152650-001
39	Hock Cover Supporting Plate B	1	152406-001	129	Screw	6	032311-302
40	Screw	2	007401-012	133	Head Rest B	1	154004-002
41	Spring Washer	2	028040-242	134	Plate	1	154005-001
88	Table Holder	2	152572-001	135	Screw	2	032311-302
89	Bolt	4	018501-622	136	Label(Right)	1	154006-001
90	Spring Washer	4	028050-242	137	Label(Left)	1	154007-001
91	Table Supporting Plate	1	152573-001	138	Encoder Label	1	154021-001
92	Bolt	1	018501-222	141	Keeping Box	1	154037-101
93	Spring Washer	1	028050-242	142	Keeping Box Cover	1	154038-001
94	Washer	1	025050-232	143	Stopper Fixing Plate	2	152592-001
95	Table Supporting Bar	1	154022-001	144	Screw	12	032311-302
96	Table(Right)	1	154019-000	145	Table Hinge	1	152589-001
97	Bolt	4	155055-001	146	Screw	1	152590-001
98	Washer	4	025040-232	151	keeping Box Cushion	1	154134-001
99	Table Center	1	152577-101	153	Spring Washer	2	028040-242
100	Bolt	4	155055-001				

Z. 付属品関係 (1)
 Accessories (1)/Zubehör (1)
 Accessoires (1)/Accesorios (1)

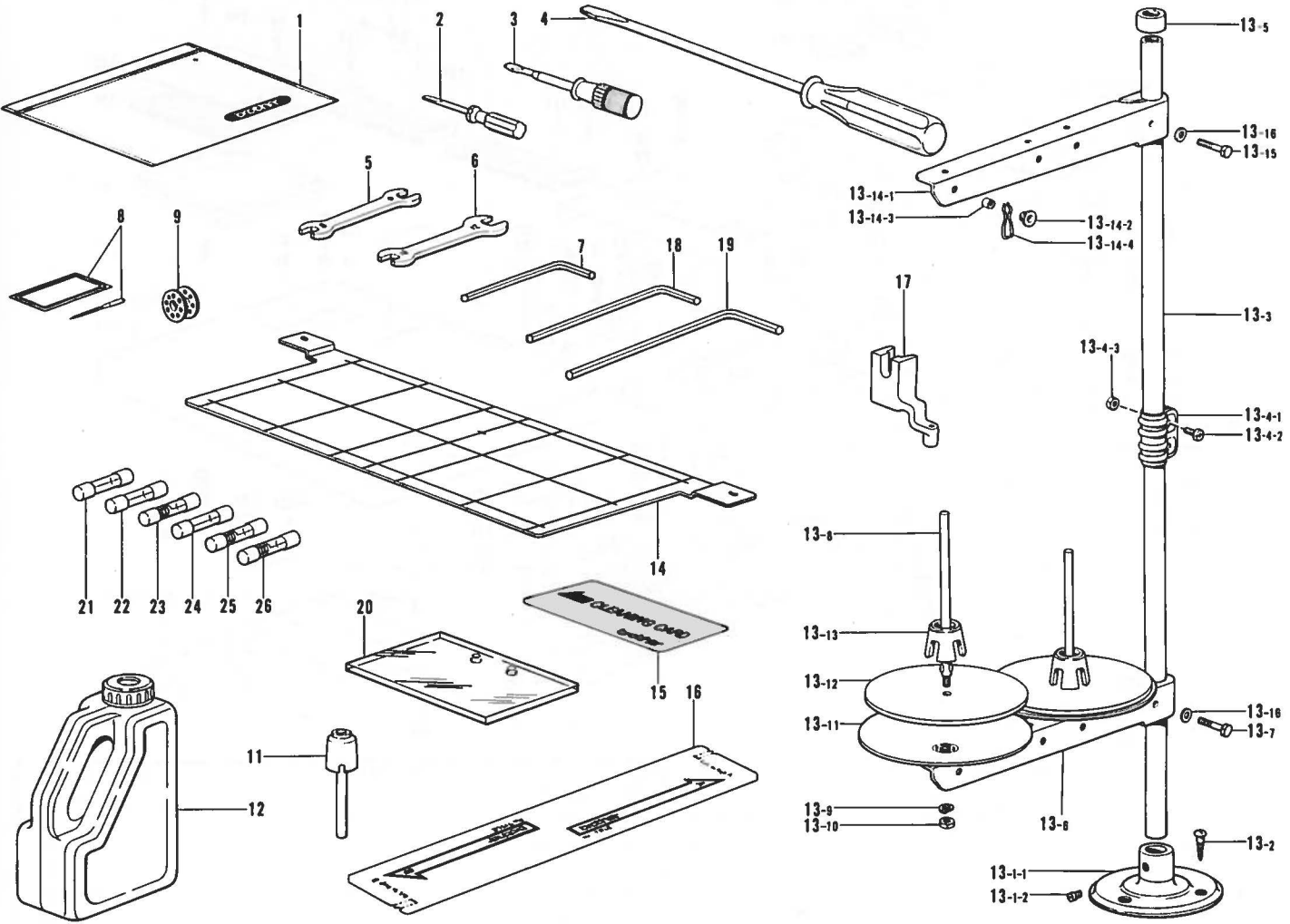

Ref. No.	Name of Parts	Q'ty	Parts No.	Ref. No.	Name of Parts	Q'ty	Parts No.
1	Vinyl Bag	1	122991-001	13- 9	Spring Washer	2	28050-243
2	Screw Driver	1	142443-001	13-10	Nut	2	021500-103
3	Screw Driver	1	118837-001	13-11	Spool Stand Base	2	150180-000
4	Screw Driver	1	101572-101	13-12	Spool Mat	2	150182-000
5	Spanner	1	100887-001	13-13	Spool Cushion	2	126863-000
6	Spanner	1	107780-001	13-14	Thread Hanger Assembly	1	150192-003
7	Spanner	1	146049-001	13-14-1	Spool Holder	1	150178-001
8	Needle	1	107415-022	13-14-2	Thread Hanger		
9	Bobbin	4	117132-001	13-14-3	Thread Bushing	2	142990-001
11	Knee Lifter Comply	1	145573-000	13-14-4	Thread Guide Spring	2	150184-001
12	Oil Tank	1	154702-001	13-15	Bolt	1	017502-803
13	Cotton Stand Assembly	1	150150-003	13-16	Washer	2	025050-233
13- 1	Cotton Stand Base Assembly	1	150139-001	14	Stand Plate	1	152515-101
13- 1-1	Cotton Stand Base	1	150189-001	15	Cleaning Card	1	152598-000
13- 1-2	Screw	2	150181-101	16	Memory Card	1	152599-000
13- 2	Screw	3	031452-203	17	Presser Foot A	1	152283-101
13- 3	Pipe	2	150172-001	18	Spanner	1	154125-001
13- 4	Joint For Cotton Stand	1	150106-001	19	Spanner	1	142721-001
13- 4-1	Joint	1	150173-001	20	Presser Plate B	1	155054-000
13- 4-2	Screw	2	150202-001	21	Fuse A	1	152479-000
13- 4-3	Nut	2	021500-103	22	Fuse B	1	152565-000
13- 5	Cap	1		23	Fuse C	1	155080-000
13- 6	Spool Holder	1	150178-001	24	Fuse D	1	152567-000
13- 7	Bolt	1	017502-803	25	Fuse E	1	152568-000
13- 8	Spool Shaft(B)	2	150179-001	26	Fuse F	1	152595-000

Z. 付属品関係 (2)
 Accessories (2) / Zubehör (2)
 Accessoires (2) / Accesorios (2)

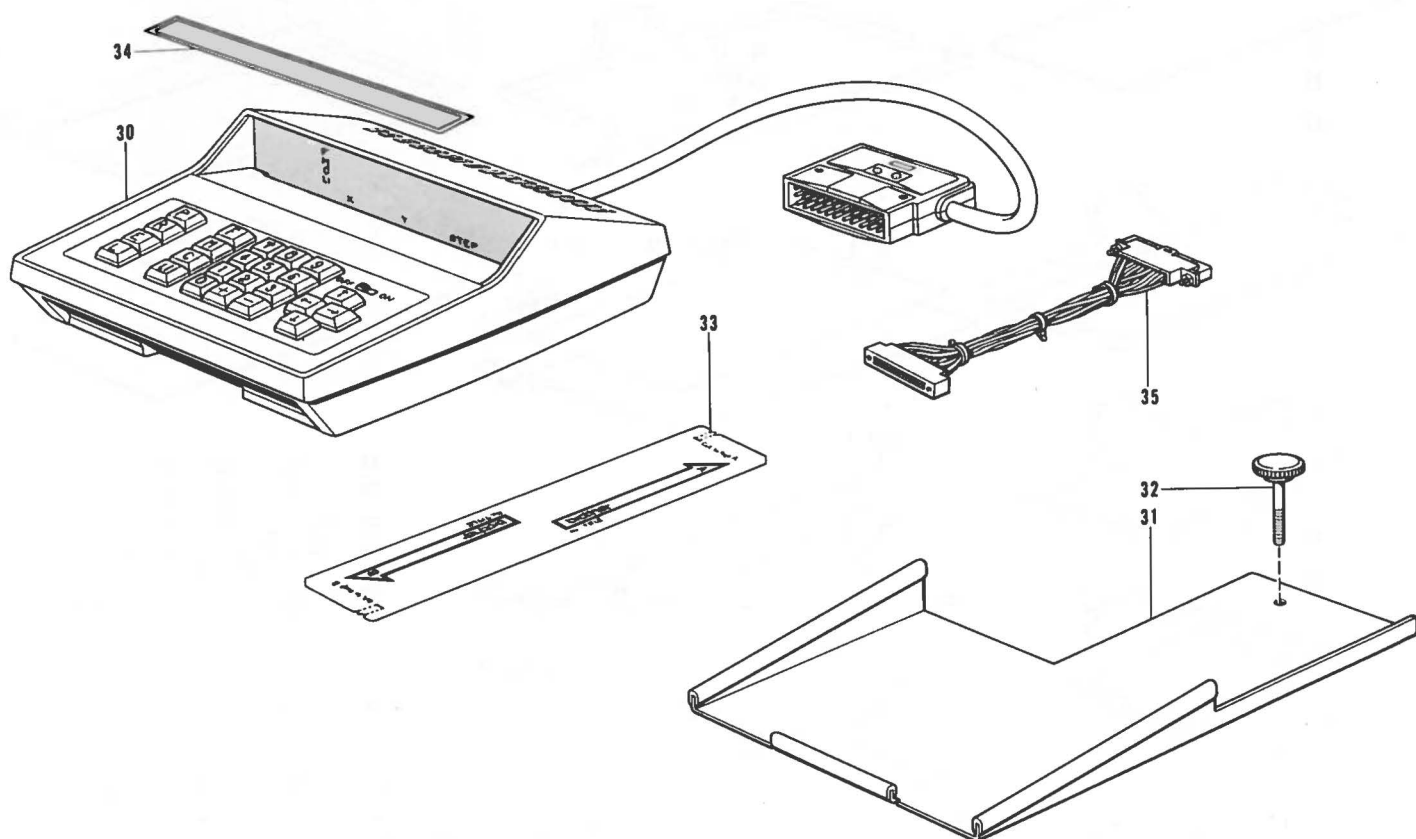

Ref. No.	Name of Parts		Q'ty	Parts No.
30	Programmer Assembly	プログラマーソウチクミ	1	152514-101
31	Table Assembly	PGM サクセイキテーブルクミ	1	S01418-001
32	Screw	PGM テーブルシメネジ	2	152590-001
33	Memory Card	ジキカード	20	152599-000
34	Programmer Seal	プログラムシール	1	
35	Programmer Harness Assembly A	プログラマーハーネスクミ A	1	152556-100

特別注文部品 (1)
 OPTION PARTS (1) / SONDERZUBEHÖR (1)
 PIECES EN OPTION (1) / PIEZAS OPCION (1)

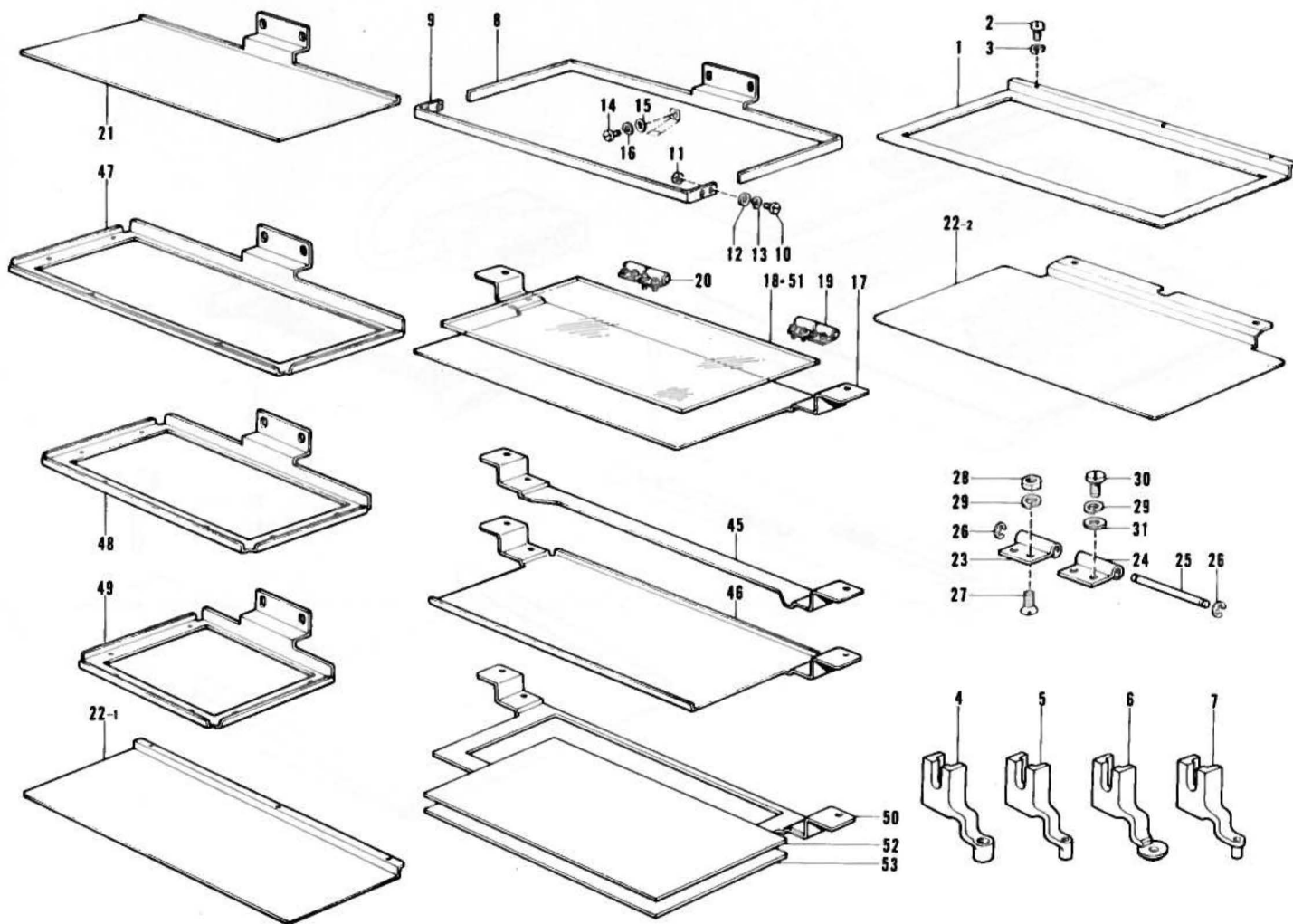

Ref. No.	Name of Parts	Q'ty	Parts No.	Ref. No.	Name of Parts	Q'ty	Parts No.
1	Feed Plate B	1	154103-001	22- 1	Feed Plate	1	152631-001
2	Screw	2	007300-403	22- 2	Feed Plate	1	154129-001
3	Spring Washer	2	028030-243	23	Hinge A	1	152627-001
4	Presser Foot B (Hole 4φ)	1	152636-001	24	Hinge B	1	152628-001
5	Presser Foot C (Hole 2φ)	1	152637-001	25	Hinge Shaft	1	152629-001
6	Presser Foot D (Hole 3φ)	1	154069-001	26	Stop Ring E	2	048020-342
7	Presser Foot E (Hole 1.6φ)	1	154089-001	27	Screw	2	003300-604
8	Rear Presser	1	152623-001	28	Nut	2	021300-103
9	Front Presser	1	152622-101	29	Spring Washer	4	028030-243
10	Screw	4	007400-813	30	Screw	2	001300-503
11	Nut	4	021400-202	31	Washer	1	025030-133
12	Washer	4	025040-232	45	Cassette	1	154071-101
13	Spring Washer	4	028040-242	46	Cassette Presser Lower	1	154091-101
14	Screw	11	001300-503	47	Presser Plate	1	154117-001
15	Washer	11	025030-233	48	Presser Plate	1	154118-101
16	Spring Washer	11	028030-243	49	Presser Plate	1	154119-101
17	Cassette Presser Lower A	1	152624-101	50	Cassette Presser	1	154120-101
18	Cassette Presser Upper	1	152625-000	51	Plate	1	155061-000
19	Hinge Assembly (R)	1	152632-001	52	Plate ABS1	1	155062-000
20	Hinge Assembly (L)	1	152633-001	53	Plate ABS2	1	155063-000
21	Presser Plate (Tacking type)	1	152630-001				

特別注文部品 (2)
 OPTION PARTS (2) / SONDERZUBEHÖR (2)
 PIECES EN OPTION (2) / PIEZAS OPCION (2)

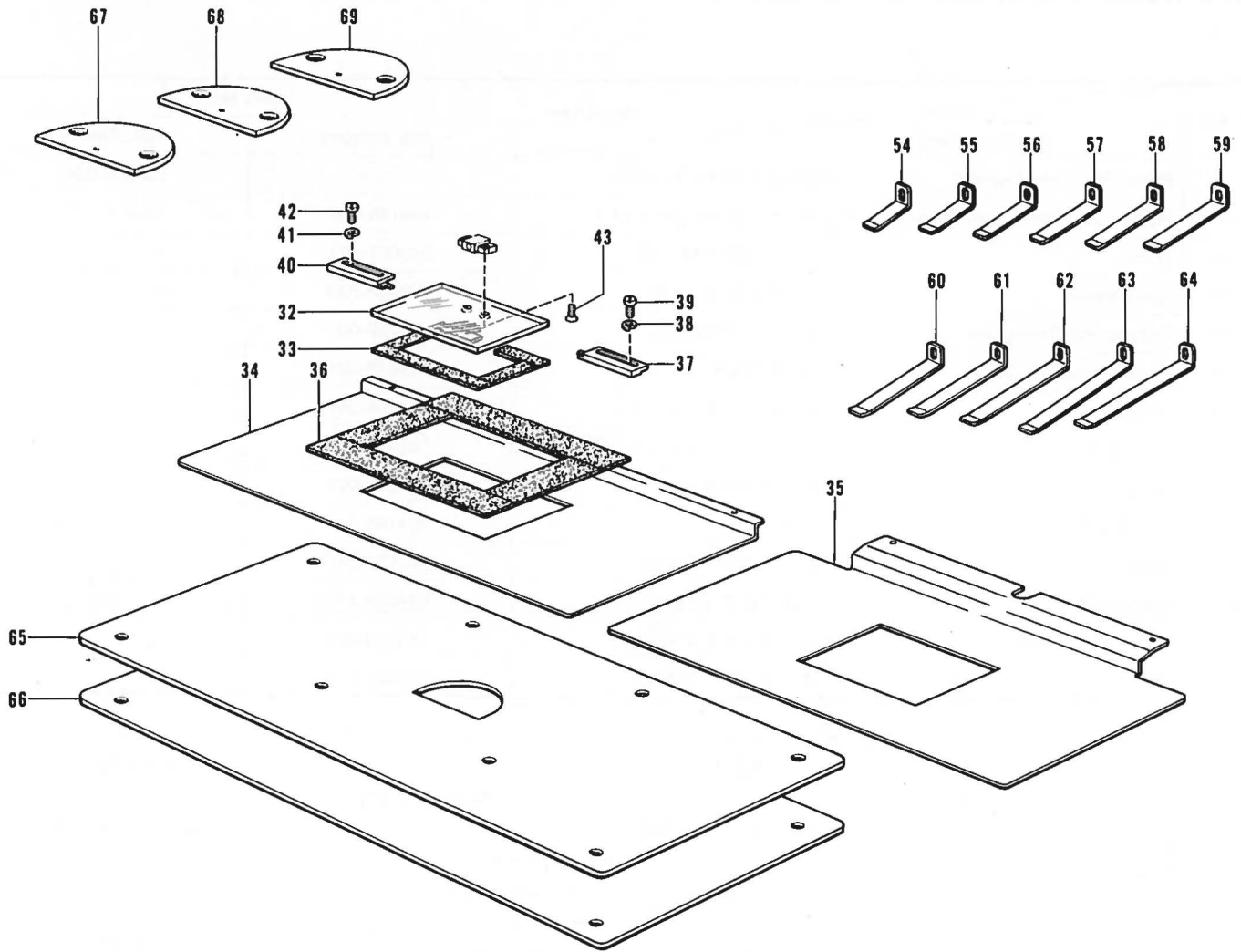

Ref. No.	Name of Parts	Qty	Parts No.	Ref. No.	Name of Parts	Qty	Parts No.
32	Presser Plate B	1	155054-000	56	Presser Plate Spring	1	152613-001
33	Friction Plate	1	154040-000	57	Presser Plate Spring	1	152618-001
34	Feed Plate (Reverse type) A	1	154042-001	58	Presser Plate Spring	1	152614-001
35	Feed Plate (Reverse type) B	1	154128-001	59	Presser Plate Spring	1	152619-001
36	Friction Plate	1	154043-000	60	Presser Plate Spring	1	152626-001
37	Positioning Right	1	154063-001	61	Presser Plate Spring	1	152615-001
38	Spring Washer	2	028030-243	62	Presser Plate Spring	1	152620-001
39	Screw	2	007300-413	63	Presser Plate Spring	1	152621-001
40	Positioning Left	1	154064-001	64	Presser Plate Spring	1	152616-001
41	Spring Washer	2	028030-243	65	Needle Plate A	1	154074-000
42	Screw	2	007300-413	66	Needle Plate B	1	154075-000
43	Screw	2	003300-604	67	Needle Plate 14	1	154104-001
54	Presser Plate Spring	1	152612-001	68	Needle Plate 18	1	154105-001
55	Presser Plate Spring	1	152617-001	69	Needle Plate 26	1	154127-001

仕様別部品一覧表

DIFFERENT PARTS LIST / ZUBEHÖRLISTE

LISTE DES PIÈCES ACCESSOIRES / LISTA DE PIEZAS ACCESORIAS

Ref. No.	Name of Parts	Sub-Class	Parts No.	
			-105 (Denim)	-205 (Denim)
C-7	Presser Bar Clamp Assembly	オサエホウダキネジツキ	-----	181919-001
C-23	Stepping Foot Driving Cam Bracket	カンケツオサエカムドダイ	154146-001	-----
C-24	Screw	ナベコ 437-40×10	062681-012	-----
C-25	Spring Washer	バネザカネ 2-4.37	028680-242	-----
C-26	Stepping Foot Driving Cam	カンケツオサエカム	154147-001	-----
C-27	Needle Cramp With Screw	ハリホウダキネジツキ	183148-001	-----
C-28	Stud Screw	カンケツオサエタンネジ	154149-001	-----
C-29	Rollar Shaft	カンケツオサエローラシク	155051-001	-----
C-30	Rollar	カンケツオサエローラ	155052-001	-----
C-31	Stop Ring E	トメワ E5	154146-001	-----
C-32	Screw	ナベコ 437-40×10	062681-012	-----
C-33	Spring Washer	バネザカネ 2-4.37	028680-242	-----
C-34	Presser Bar Bracket	カンケツオサエホウダキ	154150-001	-----
C-35	Screw	ナベコ 437-40×12	062681-212	-----

Ref. No.	品名	部品コード		Name of parts	Parts No.	
		作成器付き	作成器ナシ		with Programmer	without Programmer
M-1	スイッチパネルクミ A-2	157515-001		Switch Board Assembly B-2	157517-001	
M-33	デンゲンソウチクミ A	152466-101 (200V)		Power Supply Equip Assembly B	152659-001 (220V. 415V 380V. 440V)	
M-33	-----	-----		Power Supply Equip Assembly C	155069-001 (346V)	
M-59	ノーヒューズブレーカー A	152501-000		Fuse Breaker B	152661-000	
M-95	-----	-----		Programmer Harness Assembly	-----	152556-100
P-4	スイッチトリツケイタ A	152394-101		Black Guide Plate B	152662-001	
P-55	コネクタトリツケイタ	15416-001		Connector Setting Plate	152416-001	
P-55	ハイメンホジョカバー	152417-001		-----	-----	
P-123	デンゲンスイッチカバー	152649-001		-----	-----	
Z-30	プログラマーウチクミ	152514-101		Programmer	152514-101	
Z-31	PGMサクセイキターブルクミ	S01418-001	-----	Table Assembly	S01418-001	-----
Z-32	PGMテーブルシメネジ	152590-001	-----	Screw	152590-001	-----
Z-33	ジキカード	152599-000	-----	Memory Card	152599-000	-----
Z-35	プログラマーハーネスクミ A	152556-100	-----	Programmer Harness Assembly A	152556-100	-----

索引
INDEX / INHALTSVERZEICHNIS
INDEX / INDICE

Parts	Ref. No.	Parts	Ref. No.	Parts	Ref. No.	Parts	Ref. No.
S00839-001	C-11		P-60	018401-022	J-81		P-127
S01418-001	Z-31		P-72		K-23		P-130
S01937-001	M-60	007400-813	H-10		N-25		P-152
001021-016	M-7		K-12		N-28		P-45
001300-503	H-14		K-17		N-59		P-49
	H-30		K-20		N-61		P-53
002300-603	L-1-4		P-43	018401-222	J-63		P-64
	M-42		P-47		J-66		P-68
002300-803	M-18		P-51		N-19		P-77
	M-30		P-62	018401-622	J-31		P-98
	M-53		P-66		K-36	025040-233	L-1-24
	M-83		P-75		N-22		M-87
002301-605	M-73	007401-012	A-32	018501-222	A-48		P-155
	M-96		A-35		J-10	025050-232	N-50
002400-502	P-12		J-50		J-13		P-94
002401-003	M-15		M-88		J-33	025050-233	Z-13-16
	M-22		P-5		J-36	028020-243	M-8
	M-27		P-37		N-2	028030-242	A-39
	M-34		P-40		N-39		J-106
	M-56	007401-412	J-17		P-92		J-76
	M-86		J-53	018501-622	J-5		J-79
	P-8		J-56		J-7		J-86
	P-154		J-20		J-88		J-93
002401-012	E-59		J-23		P-89		J-96
002401-103	L-1-26		P-86	021060-102	J-99		L-1-5
002402-512	M-4	007402-013	M-43	021160-303	P-3		N-8
	M-76	007402-512	N-47	021300-103	H-28		N-32
003300-604	H-27	007403-512	J-48		P-83		P-116
	H-43	007671-212	K-9	021400-103	L-1-27	028030-243	A-54
	K-7-8	013670-712	G-43	021400-202	H-11		H-3
	K-7-10	013680-512	L-1-10		J-27		H-16
003300-812	P-110	013760-610	B-4		J-41		H-29
	P-113		B-6		J-47		H-38
003400-804	P-70		C-7-2		M-89		H-41
004300-513	L-1-3		D-5		N-44		J-110
007260-313	M-49	013761-410	D-7		N-49		M-20
007260-612	A-50	013781-012	B-11		N-55		M-32
007300-403	H-2	014300-322	L-1-7	021500-103	Z-13-4-3		M-74
007300-412	K-7-6	014400-522	J-29		Z-13-10		M-85
007300-413	H-39		M-41	025030-133	H-31		P-124
	H-42		N-16	025030-232	J-107		P-150
007300-612	J-65-6	014400-822	J-26		J-97		P-84
	J-95	014680-622	G-38		J-98	028040-242	A-33
	P-10	014710-522	C-21		N-52		A-36
007300-613	A-53	014770-622	A-46		P-115		H-13
	J-80-6	014771-022	G-3	025030-233	H-15		J-103
	K-48	017502-803	Z-13-7		L-1-31		J-18
	L-1-30		Z-13-15		M-19		J-21
	P-80	017762-013	E-53		M-31		J-24
007300-803	J-109	018082-022	M-69		M-75		J-30
	J-15-6	018102-022	P-15		P-125		J-51
	P-82		P-18		P-126		J-54
007300612	A-38		P-21	025040-232	E-60		J-57
007301-012	J-75	018103-022	P-24		H-12		J-64
	J-78		P-27		J-90		J-67
	J-85		P-30		K-33		J-82
	J-92		P-33		M-16		K-13
007301-212	N-57	018105-022	J-2		M-23		K-18
	P-114	018300-822	J-105		M-28		K-21
007302-013	P-149		N-7		M-35		K-24
007400-613	K-29		N-31		M-58		K-27
	K-42	018400-822	K-40		M-78		K-30
	P-56		N-5		M-82		K-31
007400-812	J-102		N-10		N-51		K-37
	K-4		N-13		N-53		K-43
	K-26		N-33		N-60		K-45
	M-2		N-36		N-62		M-17

Parts	Ref. No.	Parts	Ref. No.	Parts	Ref. No.	Parts	Ref. No.
	M-24		P- 118	100401-001	L- 1-21	118761-000	D- 9
	M-29		P- 120	100402-004	F- 20- 3	118762-000	D- 20
	M-36		P- 122	100463-001	E- 54	118837-001	Z- 3
	M-57		P- 129	100573-001	F- 19	122991-001	Z- 1
	M-77		P- 135	100645-003	G- 10	125925-002	D- 10
	M-81		P- 144		G- 45	126863-000	Z- 13-13
	M-84	032311-306	L- 2	100887-001	Z- 5	128060-242	K- 15
	N- 6	032452-502	P- 102	101487-000	E- 12	140004-001	B- 10- 6
	N- 11	034311-302	P- 109	101572-101	Z- 4	140378-001	D- 1
	N- 14		P- 112	101706-001	D- 13- 2	140379-001	D- 1- 1
	N- 20	048020-342	H- 26		D- 14- 2	140380-001	D- 1- 3
	N- 23		J- 15- 5	102424-004	A- 26	140382-001	D- 2
	N- 26		J- 80- 5		A- 29		D- 2- 1
	N- 29		K- 7- 5	102571-003	G- 16	140383-001	D- 2- 3
	N- 34		K- 25- 4	102630-001	B- 19	140518-001	E- 41
	N- 37	048030-342	F- 25	102716-001	E- 26	140553-102	B- 18
	N- 48	048040-342	C- 14	102843-004	G- 5	140647-001	G- 41
	P- 6		J- 65- 5	103950-003	F- 6	140726-000	B- 3
	P- 9	048050-342	C- 31	104449-001	A- 9	140885-005	F- 12
	P- 13	048060-342	G- 33		E- 2	141208-001	C- 4
	P- 153	060660-512	L- 1-15	104450-001	A- 10	142274-001	A- 13
	P- 38	060670-612	F- 29	104451-001	A- 15	142443-001	Z- 2
	P- 41		F- 33	104464-001	B- 9	142708-000	D- 4
	P- 44	060671-012	C- 6	104520-000	D- 11	142709-000	D- 6
	P- 48	062670-516	E- 34	104521-001	D- 13- 1	142721-001	Z- 19
	P- 52	062670-612	B- 24		D- 14- 1	142990-001	Z- 13-14- 3
	P- 57		F- 11	104547-001	E- 4	143882-001	P- 103
	P- 61		F- 31	104564-001	E- 18	143910-001	P- 104
	P- 63	062670-812	A- 8	104821-001	A- 12	144504-001	F- 1- 2
	P- 67		E- 27- 5	104829-101	A- 2	144869-002	E- 27- 2
	P- 73		F- 27	104830-101	A- 3	144872-001	E- 28
	P- 76	062671-012	F- 16	104832-001	A- 11	144874-001	E- 27- 4
	P- 87	062672-012	F- 15	104885-001	E- 45	144875-001	E- 27- 6
028040-243	L- 1-25	062680-712	E- 29	105234-003	G- 26	144876-001	E- 27- 7
028050-242	J- 8		F- 13	107149-001	E- 15	144878-001	E- 27- 9
	J- 11		G- 7	107155-001	E- 24	145446-001	F- 20- 5
	J- 14	062681-012	C- 24	107415-022	B- 17		L- 1-20
	J- 34		C- 32	107415-422	Z- 8	145454-001	A- 4
	J- 37		J- 69	107780-001	Z- 6	145455-002	A- 6
	J- 89		J- 72	108520-001	A- 14	145459-101	B- 2
	N- 3	062681-212	C- 27- 2	108804-001	E- 11	145461-101	B- 5
	N- 40		C- 35	108960-002	F- 18	145465-001	B- 10- 2
	P- 90		D- 16	109173-001	E- 20	145466-001	B- 10- 4
	P- 93	062711-412	G- 19	109714-000	P- 105	145472-001	C- 2
028060-242	A- 44	062761-612	A- 43	109763-002	C- 13	145474-001	C- 9
	E- 49	081001-670	E- 16	110161-004	F- 23	145475-101	C- 12
	J- 100		E- 38	110201-001	G- 39	145478-001	C- 16
	J- 60	081007-070	E- 42	110367-001	B- 12	145479-001	C- 17
028080-242	M-70	081014-670	E- 7		G- 32	145480-001	C- 18
028100-242	J- 3	100022-004	E- 44	111237-001	B- 10- 5	145481-001	C- 19
	P- 16	100032-004	A- 23	111463-001	B- 13	145482-001	C- 20
	P- 19		B- 21	111466-001	C- 1	145483-001	C- 22
	P- 22	100090-004	A- 5	111476-001	F- 17	145516-001	D- 3
	P- 25	100128-002	C- 10	111863-001	E- 19	145519-001	F- 20- 4
	P- 28	100136-001	F- 20- 8	111865-001	A- 16	145522-001	F- 10
	P- 31		L- 1-22		E- 10	145523-102	F- 14
	P- 34	100251-001	B- 7- 2	111942-001	L- 1-13	145527-000	E- 1
028260-242	A- 51		D- 1- 2	111943-001	L- 1-14	145528-000	E- 3
028350-242	K- 32		D- 1- 4	112467-002	E- 27- 8	145529-000	E- 8
028680-242	A- 27		D- 2- 2	114294-001	F- 20- 9	145534-001	E- 22
	A- 30		D- 2- 4	116112-001	F- 8	145543-001	E- 32
	C- 25		G- 27	116662-003	P- 59	145547-001	E- 33
	C- 33	100252-001	B- 8- 2	116794-001	E- 23	145571-101	L- 1-19
	J- 70	100257-010	E- 6	117132-001	D- 19	145573-000	Z- 11
	J- 73	100260-001	B- 15		Z- 9	145580-001	C- 8
031452-203	Z- 13- 2	100398-001	F- 20- 2	117936-001	A- 21	145596-001	M-91
032311-302	P- 107	100400-000	F- 5	118371-001	B- 7	145600-000	B- 10- 3

Parts	Ref. No.	Parts	Ref. No.	Parts	Ref. No.	Parts	Ref. No.
145624-000	B- 10-10	152289-000	E- 58	152383-201	A- 42	152572-001	P- 88
145681-000	M-90	152291-101	J- 1	152389-001	A- 47	152573-001	P- 91
145688-000	B- 23	152295-001	J- 6	152390-002	A- 49	152575-000	P- 69
145691-001	F- 7	152296-001	J- 9	152393-000	P- 2	152577-101	P- 99
145737-001	E- 35	152297-001	J- 12	152394-101	P- 4	152579-101	P- 106
145751-001	E- 21	152299-000	J- 15- 2	152394-101	P- 4	152580-001	P- 108
145986-001	B- 16		J- 80- 4	152395-101	P- 7	152581-001	P- 111
146037-001	E- 43		K- 7- 4	152396-100	P- 11	152589-001	P- 145
146039-001	E- 52		K- 25- 3	152397-101	P- 14	152590-001	P- 146
146040-001	E- 40	152300-001	J- 15- 3	152400-101	P- 23		Z- 32
146049-001	Z- 7	152301-001	J- 15- 4	152401-101	P- 26	152591-001	P- 119
146069-001	E- 47	152302-001	J- 16	152402-001	P- 29	152592-001	P- 121
146196-001	E- 36	152303-101	J- 19	152403-001	P- 32	152592-001	P- 143
146197-001	L- 1-23	152304-101	J- 22	152404-000	P- 35	152593-000	A- 45
146251-001	B- 22	152305-000	J- 25	152405-101	P- 36	152595-000	Z- 26
146253-000	E- 37	152307-000	J- 32	152406-001	P- 39	152598-000	Z- 15
146293-001	E- 48	152308-200	J- 35	152408-001	P- 46	152599-000	Z- 33
146314-000	E- 9	152309-001	J- 38	152409-001	P- 50		Z- 16
146327-001	E- 14	152310-001	J- 39	152410-101	P- 54		Z- 33
146333-001	E- 13	152311-001	J- 40	152416-001	P- 55	152612-001	H- 54
146367-001	E- 46	152312-001	J- 42	152417-001	P- 55	152613-001	H- 56
147141-001	E- 50	152313-001	J- 43	152419-001	P- 65	152614-001	H- 58
147326-001	B- 14	152314-001	J- 44	152420-001	P- 71	152615-001	H- 61
147496-000	E- 30	152315-001	J- 45	152422-001	P- 78	152616-001	H- 64
147511-001	B- 1	152316-001	J- 46	152423-000	P- 79	152617-001	H- 55
147513-001	C- 7- 1	152317-101	J- 49	152424-001	P- 81	152618-001	H- 57
147557-101	F- 4	152318-001	J- 52	152425-001	P- 85	152619-001	H- 59
147777-000	B- 10- 9	152319-001	J- 55	152433-101	M- 3	152620-001	H- 62
148350-010	D- 18	152320-001	J- 58	152437-200	M- 5	152621-001	H- 63
148537-001	G- 13	152322-001	J- 61	152440-101	M- 6	152622-101	H- 9
148849-001	E- 27- 3	152326-001	J- 65- 3	152444-101	M- 9	152623-001	H- 8
148924-101	F- 20- 7	152327-000	J- 65- 4	152446-101	M-10	152624-101	H- 17
148967-101	D- 18- 4	152333-001	J- 80- 2	152451-100	M-11	152625-000	H- 18
149135-101	F- 32		K- 7- 2	152452-001	M-12	152626-001	H- 60
149313-101	B- 10	152334-001	J- 80- 3		M-26	152627-001	H- 23
150106-001	Z- 13- 4		K- 7- 3	152453-001	M-13	152628-001	H- 24
150139-001	Z- 13- 1	152335-000	J- 83	152454-100	M-14	152629-001	H- 25
150150-003	Z- 13	152336-001	J- 84	152461-001	M-21	152630-001	H- 21
150172-001	Z- 13- 3	152337-001	J- 87	152463-101	M-25	152631-001	H- 22- 1
150173-001	Z- 13- 4- 1	152338-001	K- 1	152466-101	M-33	152632-001	H- 19
150178-001	Z- 13- 6	152339-001	K- 2	152479-000	Z- 21	152633-001	H- 20
	Z- 13-14- 1	152340-101	K- 3	152480-000	M-37	152634-001	A- 40
150179-001	Z- 13- 8	152342-101	K- 5	152487-201	M-38	152636-001	H- 4
150180-000	Z- 13-11	152344-001	K- 7- 7	152488-001	M-39	152637-001	H- 5
150181-101	Z- 13- 1- 2	152345-001	K- 7- 9	152491-000	M-45	152640-001	N- 35
150182-000	Z- 13-12	152346-101	K- 8	152493-000	M-47	152642-001	J- 65- 2
150184-001	Z- 13-14- 4	152348-001	K- 11	152496-001	M-50	152643-001	K- 34
150189-001	Z- 13- 1- 1	152349-101	K- 16	152497-001	M-51	152644-001	K- 35
150192-003	Z- 13-14	152350-101	K- 19	152498-001	M-52	152645-001	L- 1-29
150202-001	Z- 13- 4- 2	152351-101	K- 22	152499-101	M-54	152646-101	P- 17
151074-001	E- 5	152353-001	K- 25- 2	152500-000	M-55	152648-001	J- 91
151594-001	B- 20	152358-001	L- 1- 6	152501-000	M-59	152649-001	P- 123
151602-002	F- 3	152361-001	L- 1-11	152504-000	M-65	152650-001	P- 128
151607-001	D- 12	152362-001	L- 1-12	152505-001	L- 1-28	152651-201	L- 1
	G- 23	152363-001	L- 1-16	152506-000	L- 1-28- 1	152652-001	J- 15
151987-001	G- 15	152364-001	L- 1-18	152510-000	M-66	152659-001	M-33
152255-000	A- 22	152365-101	N- 1	152513-101	M-71	152661-000	M-59
152256-001	A- 24	152366-101	N- 4	152514-101	Z- 30	152662-001	P- 4
152257-001	A- 25	152368-001	N- 12	152515-101	Z- 14	152670-001	K- 7
152258-101	A- 28	152369-001	N- 15	152516-100	M-72	152671-001	K- 25
152259-101	A- 31	152370-000	N- 17	152544-000	M-79	152673-001	J- 80
152283-101	Z- 17	152371-001	N- 18		P- 148	153483-001	F- 9
152284-100	E- 39	152372-001	N- 21	152556-100	M-95	154004-002	P- 133
152285-001	E- 51	152374-001	N- 27		Z- 35	154005-001	P- 134
152286-001	E- 55	152375-001	N- 30	152565-000	Z- 22	154006-001	P- 136
152287-001	E- 56	152381-101	N- 45	152567-000	Z- 24	154007-001	P- 137
152288-000	E- 57	152382-101	N- 46	152568-000	Z- 25	154008-001	J- 65

Parts	Ref. No.	Parts	Ref. No.	Parts	Ref. No.	Parts	Ref. No.
154010-001	J- 68	154148-001	C- 27- 1	155079-001	P- 74		
154011-001	J- 71	154149-001	C- 28	155080-000	Z- 23		
154012-001	J- 74	154150-001	C- 34	155347-001	F- 34		
154013-001	J- 77	154550-001	C- 15	155510-001	F- 1- 4		
154014-001	J- 94	154552-001	D- 8	155558-001	G- 40		
154015-001	J- 62	154554-001	E- 25	155559-001	G- 42		
154016-001	P- 1	154555-001	E- 31	155578-000	G- 44		
154017-101	P- 42	154559-001	F- 1- 1	155690-001	D- 17		
154018-101	N- 9	154562-001	F- 1- 3	156641-001	E- 17		
154019-000	P- 96	154563-001	F- 2	157216-001	P- 140		
154020-000	P- 101	154566-001	G- 1	157505-001	C- 3		
154021-001	P- 138	154567-000	G- 2	157510-000	K- 10		
154022-001	P- 95	154568-001	G- 4	157511-001	M-40		
154023-000	K- 38	154569-001	G- 6	157512-000	M-44		
154024-001	L- 1- 8	154570-001	G- 8	157513-000	M-46		
154032-002	A- 52	154571-001	G- 9	157514-000	M-48		
154033-000	P- 139	154574-001	G- 11	157515-001	M- 1		
154036-000	M-80	154575-001	G- 12	157517-001	M- 1		
154037-101	P- 141	154576-001	G- 14	158597-001	L- 1-32		
154038-001	P- 142	154577-001	G- 17	158726-001	B- 10-11		
154040-000	H- 33	154578-000	G- 18	158727-001	B- 10-12		
154042-001	H- 34	154579-001	G- 20	159324-001	D- 15		
154043-000	H- 36	154580-001	G- 21	159698-001	B- 8		
154063-001	H- 37	154581-001	G- 22	159805-001	F- 20- 6		
154064-001	H- 40	154582-001	G- 24	181429-101	B- 10- 7		
154067-001	N- 54	154590-001	G- 25	181476-201	E- 27		
154069-001	H- 6	154593-001	G- 28	181919-001	C- 7		
154070-001	K- 6	154594-000	G- 29	181995-001	D- 13		
154071-101	H- 45	154595-001	G- 30		D- 14		
154074-000	H- 65	154596-000	G- 31	183125-001	F- 1		
154075-000	H- 66	154597-001	G- 34	183129-001	F- 20		
154089-001	H- 7	154598-001	G- 35	183148-001	C- 27		
154090-001	N- 56	154599-000	G- 36	183291-001	D- 18- 1		
154091-101	H- 46	154600-001	G- 37	183292-001	D- 18- 2		
154092-001	L- 1- 9	154601-001	F- 21	183293-001	D- 18- 3		
154094-001	J- 4	154602-001	F- 22	28050-243	Z- 13- 9		
154097-000	P- 147	154603-001	F- 24	525664-000	M-61		
154098-001	K- 39	154606-001	F- 26	525907-000	M-62		
154100-000	K- 44	154607-001	F- 28	552851-001	L- 1-28- 5		
154101-101	K- 46	154608-001	F- 30	552908-000	M-64		
154102-000	K- 47	154702-001	Z- 12	554482-000	E- 61		
154103-001	H- 1	155001-001	M-67		M-63		
154104-001	H- 67	155033-001	M-68				
154105-001	H- 68	155051-001	C- 29				
154113-001	J- 59	155052-001	C- 30				
	K- 14	155053-001	P- 20				
154114-101	N- 38	155054-000	H- 32				
154115-001	C- 5		Z- 20				
154117-001	H- 47	155055-001	P- 100				
154118-101	H- 48		P- 97				
154119-101	H- 49	155056-001	J- 28				
154120-101	H- 50	155058-001	J- 101				
154121-001	A- 37	155059-001	J- 104				
154122-001	A- 34	155060-001	J- 108				
154123-001	A- 41	155061-000	H- 51				
154124-001	N- 24	155062-000	H- 52				
154125-001	Z- 18	155063-000	H- 53				
154127-001	H- 69	155068-001	P- 117				
154128-001	H- 35	155069-001	M-33				
154129-001	H- 22- 2	155070-001	N- 43				
154134-001	P- 151	155071-001	N- 58				
154136-001	M-92	155073-001	K- 28				
154139-000	M-93	155074-001	K- 41				
154144-000	M-94	155075-001	N- 41				
154146-001	C- 23	155076-001	N- 42				
154146-001	C- 23	155077-000	E- 62				
154147-001	C- 26	155078-001	P- 58				

ブラザー工業株式会社

〒467 名古屋市瑞穂区堀田通 9-35
電話 (052) 824-2511代

BROTHER INDUSTRIES, LTD. NAGOYA, JAPAN

151-302
195302-101
1984, 7

From the library of: Superior Sewing Machine & Supply, LLC

Printed in Japan/Construido en Japón/Imprimé au Japon/Impreso en Japón